



# MASTERColour CDM-R Elite

MASTERColour CDM-R Elite 70W/942 E27 PAR30L 40D

Compact, very high-efficiency, long-life Ceramic Metal Halide discharge reflector lamp producing crisp white sparkling light with high color rendering

## Product data

### • General Characteristics

Cap-Base	E27
Bulb	PAR30L [PAR 3.75 inch/95mm Long]
Bulb Finish	Clear
Operating Position	any [Any or Universal (U)]
Life to 5% failures EL	9000 hr
Life to 10% failures EL	10000 hr
Life to 20% failures EL	12000 hr
Life to 50% failures EL	15000 hr

### • Light Technical Characteristics

Beam Description	Flood [Flood]
Beam Angle	40 D
Beam Angle Technical	29 (min), 38 (nom), 47 (max) D
Luminous Intensity	9800 cd
Color Code	942 [CCT of 4200K]
Color Rendering Index	89 (min), 92 (nom) Ra8
Color Designation (text)	Cool White
Color Temperature	4200 K
Color Temperature Technical	4200 K
Luminous Flux Lamp EL	5200 Lm
Forward Luminous Output	4700 (min), 5200 (nom) Lm
Forward Luminous Efficacy	71 Lm/W
LLMF - end nominal lifetime	75 %

Forward Lum Maintenance 2000h	90 %
Forward Lum Maintenance 4000h	84 %
Forward Lum Maintenance 8000h	80 %
Forward Lum Maintenance 12000h	77 %
Forward Lum Maintenance 15000h	75 %
Design Mean Lumens	4200 Lm
Chromaticity Coordinate X	0.372 -
Chromaticity Coordinate Y	0.369 -
Luminous flux in 90° cone	4500 Lm

### • Electrical Characteristics

System Power EL	80 W
Lamp Wattage	70 W
Lamp Wattage EL	70 W
Lamp Wattage EL 25°C, Rated	73 W
Lamp Voltage	90 V
Lamp Current EL	0.810 A
Ignition Time	30 (max) s
Run-up time 90%	3 (max) min
Re-ignition Time [min]	15 (max) min
Dimmable	No
Warm-up Time to 60% Light Outp	120 s

**PHILIPS**

# MASTERColour CDM-R Elite

## • Environmental Characteristics

Energy Efficiency Label (EEL)	A
Mercury (Hg) Content	6.5 mg
Energy consumption kWh/1000h	80 kWh

## • Measuring Conditions

Switching cycle	1350X
-----------------	-------

## • Luminaire Design Requirements

Cap-Base Temperature	200 (max) C
Bulb Temperature	300 (max) C

## • Product Dimensions

Overall Length C	123 (max) mm
Diameter D	97 (max) mm

Overall Length C [inch] 4.84 (max) in

## • Product Data

Order code	928053100630
Full product code	928053100630
Full product name	MASTERColour CDM-R Elite 70W/942 E27 PAR30L 40D
Order product name	MC CDM-R Elite 70W/942 E27 PAR30L 40D
Pieces per pack	1
Packing configuration	6
Packs per outerbox	6
Bar code on pack - EAN1	8718291651697
Bar code on outerbox - EAN3	8718291651703
Logistic code(s) - 12NC	928053100630
Net weight per piece	0.225 kg

## Warnings and Safety

- Use only with electronic control gear
- Control gear must include end-of-life protection (IEC61167, IEC 62035)

- A lamp breaking is extremely unlikely to have any impact on your health. If a lamp breaks, ventilate the room for 30 minutes and remove the parts, preferably with gloves. Put them in a sealed plastic bag and take it to your local waste facilities for recycling. Do not use a vacuum cleaner.

## Dimensional drawing

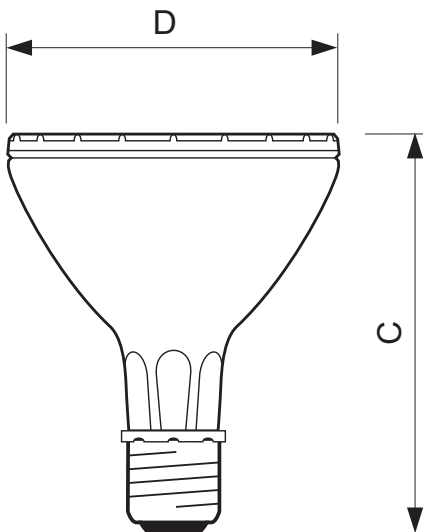

E27

## MASTERColour CDM-R Elite 70W/942 E27 PAR30L 40D

Product	C (Max)	D (Max)
CDM-R Elite 70W/942 E27 PAR30L 40D	123	97

Photometric data

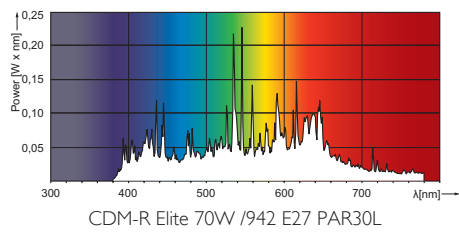

© 2015 Koninklijke Philips N.V. (Royal Philips)  
All rights reserved.

Specifications are subject to change without notice. Trademarks are the property of Koninklijke Philips N.V. (Royal Philips) or their respective owners.

[www.philips.com/lighting](http://www.philips.com/lighting)

2015, July 11  
data subject to change