



# HF-Regulator II for TL-D lamps

HF-R 158 TL-D EII 220-240V 50/60Hz

High-frequency electronic dimming ballast, using the analog protocol (1-10 V) for TL-D lamps

## Product data

### • General Information

Application Code	EII
Type Version	mk2
Lamp Type	TL-D
Number Of Lamps	1 piece/unit
Number Of Products On MCB (16A Type B) (Nom)	28
Automatic Restart	Yes

### • Operating and Electrical

Input Voltage	220 to 240 V
Input Frequency	50-60_1 Hz
Operating Frequency (Max)	105 kHz
Operating Frequency (Min)	45 kHz
Ignition Method	Programmed Start
Crestfactor (Max)	1.7
Power Factor 100% Load (Nom)	0.97
Ignition Time (Max)	0.2 s
Mains Voltage Performance (AC)	-8%+6%
Mains Voltage Safety (AC)	-10%+10%
Earth Leakage Current (Max)	0.5 mA
Inrush Current Width	0.25 ms
Power Losses (Nom)	6.3 W
Inrush Current Peak (Max)	27 A

### • Wiring

Connector Type Input Terminals	WAGO 251 universal connector [ Suitable for both automatic wiring (ALF and ADS) and manual wiring]
Connector Type Output Terminals	WAGO 251 universal connector [ Suitable for both automatic wiring (ALF and ADS) and manual wiring]
Connector Type Control Input Terminals	WAGO 251 universal connector [ Suitable for both automatic wiring (ALF and ADS) and manual wiring]
Wire Striplength	8.0-9.0 mm
Dual Fixture Master/Slave	Not applicable [ Master/Slave oper. not applicable]
Control Input Terminal Cross Section	0.50-1.00 mm <sup>2</sup>
Input Terminal Cross Section	0.50-1.00 mm <sup>2</sup>
Output Terminal Cross Section	0.50-1.00 mm <sup>2</sup>
Auto Insert (ALF/ADS) Wire Cross Section	0.5 mm <sup>2</sup>

### • System characteristics

Rated Ballast-Lamp Power	58 W
--------------------------	------

### • Temperature

T-Ambient (Max)	50 °C
T-Ambient (Min)	-20 °C
T-Storage (Max)	80 °C
T-Storage (Min)	-25 °C
Stable Lamp Operation Temperature	Not specified

**PHILIPS**

# HF-Regulator II for TL-D lamps

T-Ignition (Max) 50 °C  
 T-Ignition (Min) 0 °C

### • Controls and Dimming

Control Interface 1-10V  
 Regulating Level 1%-100%  
 Power  
 Control Input Yes (Basic insulation)  
 Protection

### • Mechanical and Housing

Housing L 360x30x21

### • Emergency Operation

Battery Voltage Lamp Ignition 196 V  
 Battery Voltage Lamp Operation 154-276

### • Approval and Application

Energy Efficiency Index A1  
 EMI 9 kHz ... 30 MHz EN55015  
 EMI 30 MHz ... 1000 MHz Level = Class  
 Safety Standard IEC 61347-2-3  
 Performance Standard IEC 60929

Quality Standard ISO 9000:2000  
 Environmental Standard ISO 14001  
 Harmonic Current Emission Standard IEC 61000-3-2  
 EMC Immunity Standard IEC 61547  
 Vibration Standard IEC 68-2-6 Fc  
 Bumps Standard IEC 68-2-29 Eb  
 Humidity Standard EN 61347-2-3 clause 11  
 Temperature Marking Yes  
 Emergency Standard IEC 60598-2-22  
 Hum And Noise Level Inaudible

### • Product Data

Full product code 871150091017230  
 Order product name HF-R 158 TL-D EII 220-240V 50/60Hz  
 EAN/UPC - Product Code 8711500910172  
 Order code 913700609466  
 Numerator - Quantity Per Pack 1  
 Numerator - Packs per outer box 12  
 Material Nr. (12NC) 913700609466  
 Net Weight (Piece) 0.270 kg

## Dimensional drawing

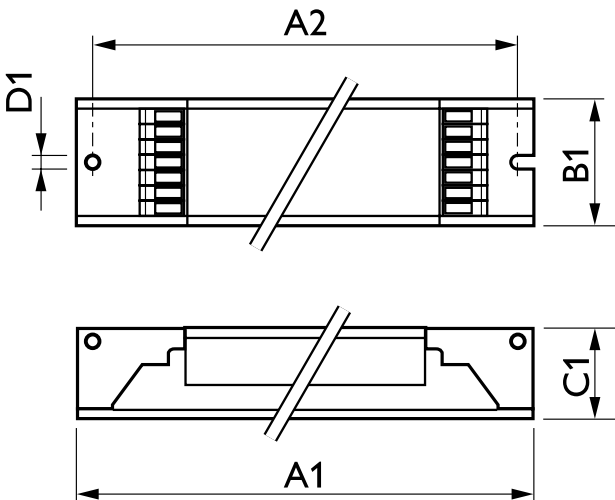

### HF-R 158 TL-D EII 220-240V 50/60Hz

Product	D1	C1	A1	A2	B1
HF-R 158 TL-D EII 220-240V 50/60Hz	4.2 mm	22 mm	360 mm	350 mm	30 mm

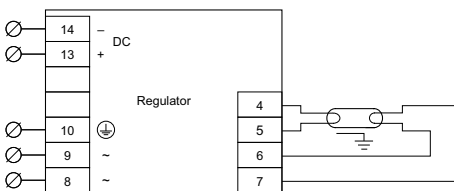

HF-R 1 lamp TL5/PL-L/TL-D



© 2015 Philips Lighting Holding B.V.  
All rights reserved.

Specifications are subject to change without notice. Trademarks are the property of Koninklijke Philips N.V. (Royal Philips) or their respective owners.

[www.philips.com/lighting](http://www.philips.com/lighting)

2015, December 24  
data subject to change