



HF-Regulator II for TL-D lamps

HF-R 258 TL-D EII 220-240V 50/60Hz

High-frequency electronic dimming ballast, using the analog protocol (1-10 V) for TL-D lamps

Product data

• General Information

Application Code	EII
Type Version	mk2
Lamp Type	TL-D
Number Of Lamps	2 piece/unit
Number Of Products On MCB (16A Type B) (Nom)	12
Automatic Restart	Yes

• Operating and Electrical

Input Voltage	220 to 240 V
Input Frequency	50-60_1 Hz
Operating Frequency (Max)	105 kHz
Operating Frequency (Min)	45 kHz
Ignition Method	Programmed Start
Crestfactor (Max)	1.7
Power Factor 100% Load (Nom)	0.98
Ignition Time (Max)	0.2 s
Mains Voltage Performance (AC)	-8%+6%
Mains Voltage Safety (AC)	-10%+10%
Earth Leakage Current (Max)	0.5 mA
Inrush Current Width	0.40 ms
Power Losses (Nom)	11.2 W
Inrush Current Peak (Max)	45 A

• Wiring

Connector Type	WAGO 251 universal connector
Input Terminals	[Suitable for both automatic wiring (ALF and ADS) and manual wiring]
Connector Type	WAGO 251 universal connector
Output Terminals	[Suitable for both automatic wiring (ALF and ADS) and manual wiring]
Connector Type	WAGO 251 universal connector
Control Input Terminals	[Suitable for both automatic wiring (ALF and ADS) and manual wiring]
Wire Striplength	8.0-9.0 mm
Dual Fixture Master/Slave	- [not specified]
Control Input Terminal Cross Section	0.50-1.00 mm ²
Input Terminal Cross Section	0.50-1.00 mm ²
Output Terminal Cross Section	0.50-1.00 mm ²
Auto Insert (ALF/ADS) Wire Cross Section	0.5 mm ²

• System characteristics

Rated Ballast-Lamp Power	58 W
--------------------------	------

• Temperature

T-Ambient (Max)	50 °C
T-Ambient (Min)	10 °C
T-Storage (Max)	80 °C
T-Storage (Min)	-25 °C
Stable Lamp Operation Temperature	Not specified

PHILIPS

HF-Regulator II for TL-D lamps

T-Ignition (Max) 50 °C
 T-Ignition (Min) 0 °C

• Controls and Dimming

Control Interface 1-10V
 Regulating Level 1%-100%
 Power
 Control Input Yes (Basic insulation)
 Protection

• Mechanical and Housing

Housing L 360x30x21

• Emergency Operation

Battery Voltage Lamp Ignition 196 V
 Battery Voltage Lamp Operation 154-276

• Approval and Application

Energy Efficiency Index A1
 EMI 9 kHz ... 30 MHz EN55015
 EMI 30 MHz ... 1000 MHz Level = Class
 Safety Standard IEC 61347-2-3
 Performance Standard IEC 60929

Quality Standard ISO 9000:2000
 Environmental Standard ISO 14001
 Harmonic Current Emission Standard IEC 61000-3-2
 EMC Immunity Standard IEC 61547
 Vibration Standard IEC 68-2-6 Fc
 Bumps Standard IEC 68-2-29 Eb
 Humidity Standard EN 61347-2-3 clause 11
 Temperature Marking Yes
 Emergency Standard IEC 60598-2-22
 Hum And Noise Level Inaudible

• Product Data

Full product code 871150091019630
 Order product name HF-R 258 TL-D EII 220-240V 50/60Hz
 EAN/UPC - Product Code 8711500910196
 Order code 913700609566
 Numerator - Quantity Per Pack 1
 Numerator - Packs per outer box 12
 Material Nr. (12NC) 913700609566
 Net Weight (Piece) 0.325 kg

Dimensional drawing

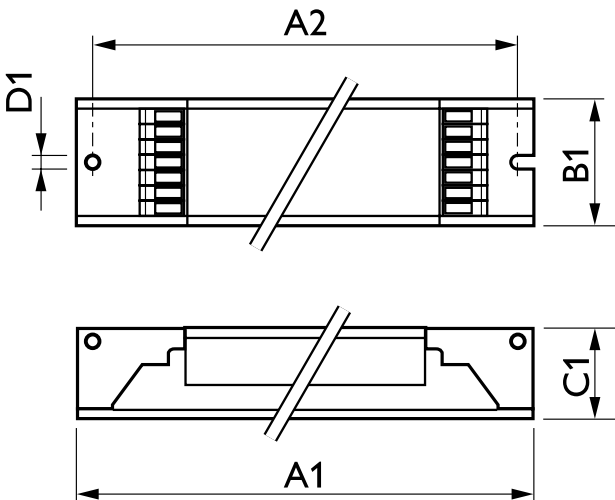

HF-R 258 TL-D EII 220-240V 50/60Hz

Product	D1	C1	A1	A2	B1
HF-R 258 TL-D EII 220-240V 50/60Hz	4.2 mm	22 mm	360 mm	350 mm	30 mm

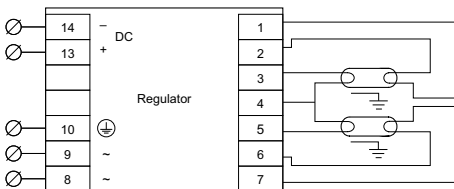

HF-R 2 lamps TL5/PL-L/TL-D



© 2015 Philips Lighting Holding B.V.
All rights reserved.

Specifications are subject to change without notice. Trademarks are the property of Koninklijke Philips N.V. (Royal Philips) or their respective owners.

www.philips.com/lighting

2015, December 24
data subject to change