

ALL RIGHTS RESERVED. REPRODUCTION OR ISSUE TO THIRD PARTIES IN ANY FORM WHATSOEVER IS NOT PERMITTED WITHOUT WRITTEN AUTHORITY FROM THE PROPRIETORS.

HER HAKKI MAHFUZDUR. YAZILI IZIN OLMADAN DOKÜMANLARIN HIÇ BİR KISMI KOPYA, KAYIT, BASIM VEYA DİĞER HERHANGİ BİR ŞEKİLDE ÇOĞALTILMAZ VE YAYINLANMAZ.

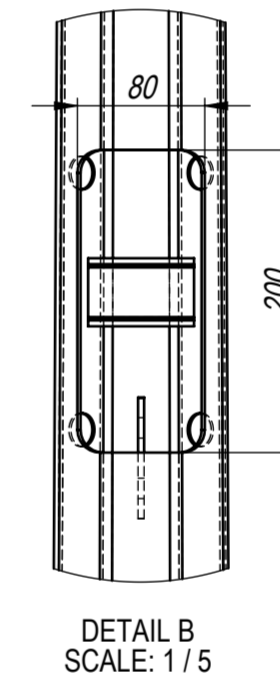
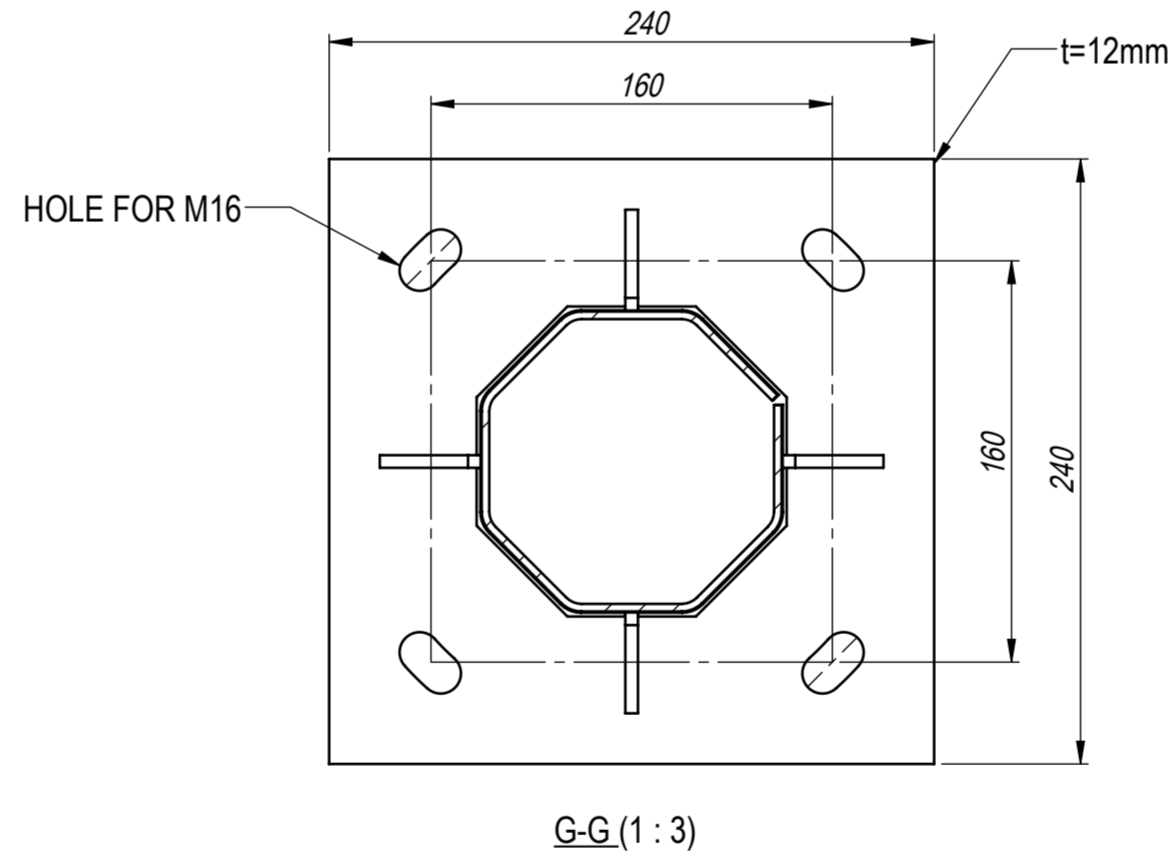
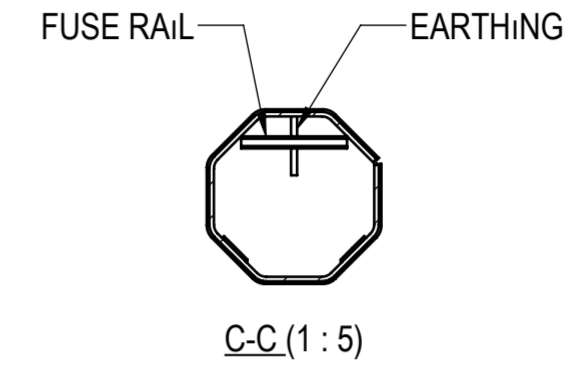
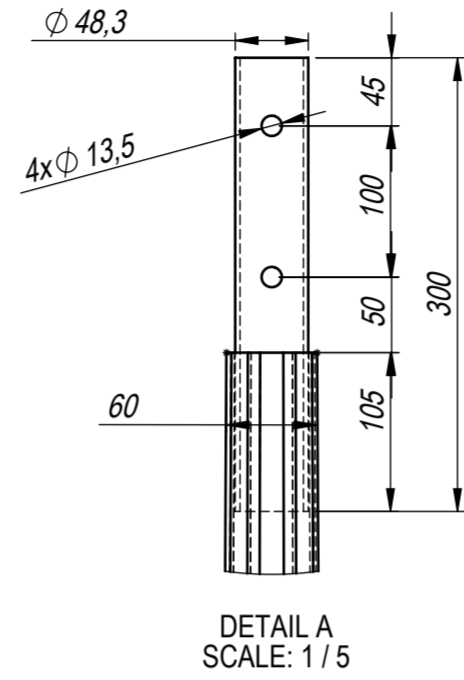
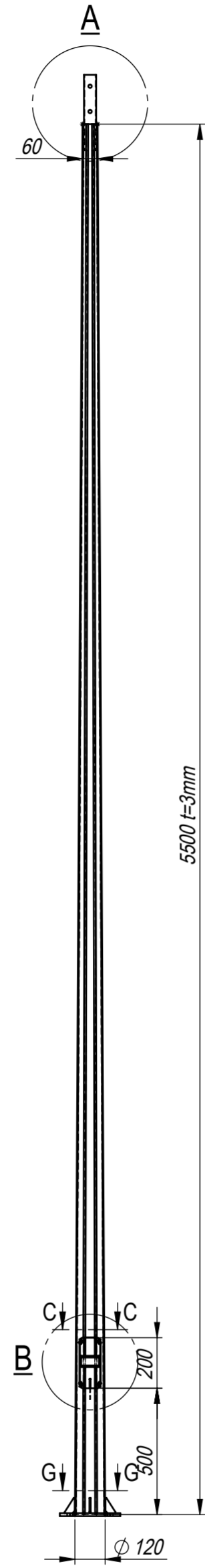
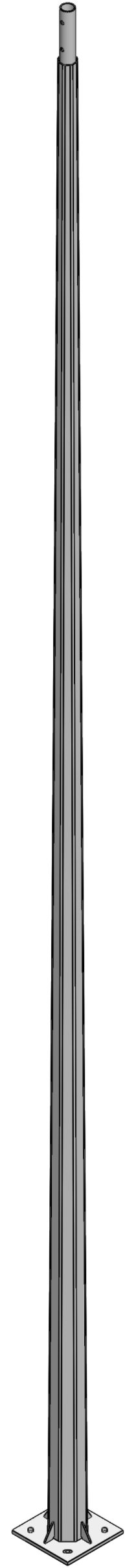

### ANCHOR SET: AC SET 2

| REVİZYONLAR / REVISIONS  |                      |               |                     |                                 |  |          |
|--|----------------------|---------------|---------------------|---------------------------------|--|----------|
| REV.   | TANIM<br>DESCRIPTION | TARİH<br>DATE | ONAY<br>APPROVED    |                                 |  |          |
| <b>GENEL NOTLAR</b><br>GENERAL NOTES   |                      |               |                     |                                 |  |          |
| TÜM ÖLÇÜLER mm'DİR.<br>ALL DIMENSIONS ARE IN mm.   |                      |               |                     |                                 |  |          |
| TÜM ÇELİK ELEMANLAR, CIVATA, SOMUN VE RONDİLALAR SICAK DALDIRMA GALVANİZDİR. (EN ISO 1461)   |                      |               |                     |                                 |  |          |
| ALL STEEL ITEMS, BOLTS, NUTS & WASHERS TO BE HOT-DIP GALV. AS PER (EN ISO 1461)  |                      |               |                     |                                 |  |          |
| TASARIM KRİTERLERİNE GÖRE CIVATALAR (ISO 898) 5.8 & 6.8 & 8.8 OLARAK KULLANILABİLİR.<br>BOLTS CAN BE USED AS (ISO 898) 5.8 & 6.8 & 8.8 ACCORDING TO DESIGN CRITERIA. |                      |               |                     |                                 |  |          |
| ADI - SOYADI<br>NAME - SURNAME   | TARİH<br>DATE        | İMZA<br>SIGN  | MALZEME<br>MATERIAL | TASARIM NOTLARI<br>DESIGN NOTES |  |          |
| CİZEN<br>DRAWN BY  | NEKAPLAN             | 17.12.2019    | GÖVDE<br>SHAFT      | S235                            | TASARIM RÜZGAR HIZI<br>DESIGN WIND SPEED | 130 km/H |
| KONTROL<br>CONTROL   | I.YUCEL              | 17.12.2019    | FLANŞ<br>FLANGE     | S235                            | GÜVENLİK KATSAYISI<br>FACTOR OF SAFETY   | 1.67     |
| ONAY<br>APPROVAL   | K.CANBALOGLU         | 17.12.2019    | DİĞER<br>OTHER      | S235                            | TASARIM STANDARTI<br>DESIGN STANDART     |          |

### PAD2-60-15 OUTLINE

|                            |            |              |                |          |    |
|----------------------------|------------|--------------|----------------|----------|----|
| SİPTEK. NO<br>ORDER NUMBER | STANDART   |              |                | REV<br>0 |    |
| PAFTA NO<br>DRAWING NUMBER | PAD2-60-15 |              |                |          |    |
| TARİH<br>DATE              | 19.12.2019 |              |                |          |    |
| AGIRLIK<br>WEIGHT          |            |              |                |          |    |
| BÖLÜM<br>DEPARTMENT        | POLİGON    | SHEET 1 OF 1 | ÖLÇEK<br>SCALE | 1:50     | A2 |

