

ALL RIGHTS RESERVED. REPRODUCTION OR ISSUE TO THIRD PARTIES IN ANY FORM WHATSOEVER IS NOT PERMITTED WITHOUT WRITTEN AUTHORITY FROM THE PROPRIETORS.

HER HAKKI MAHFUZDUR. YAZILI IZIN OLMADAN DOKÜMANLARIN HIÇ BİR KISMI KOPYA, KAYIT, BASIM VEYA DİĞER HERHANGİ BİR ŞEKİLDE ÇOĞALTILAMAZ VE YAYINLANAMAZ.

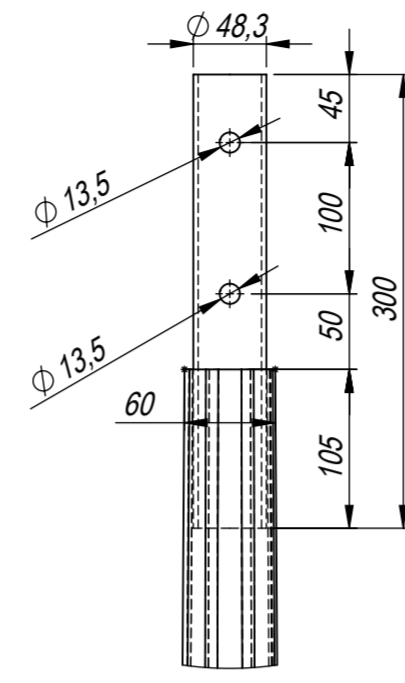

DETAIL C
SCALE: 1/5

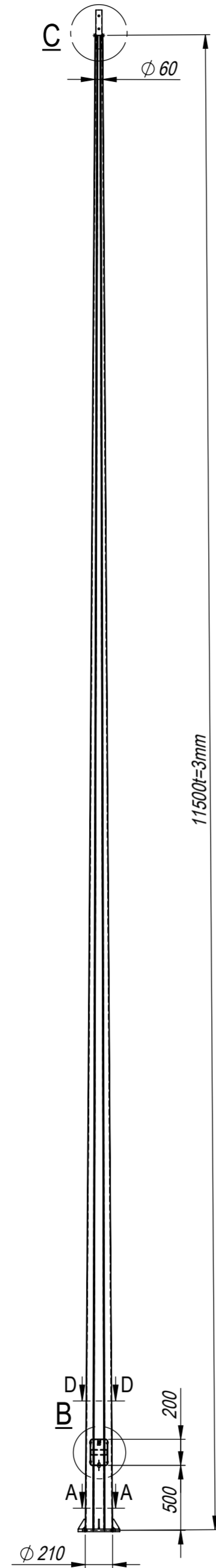
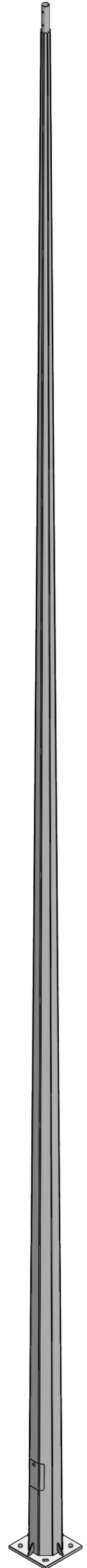
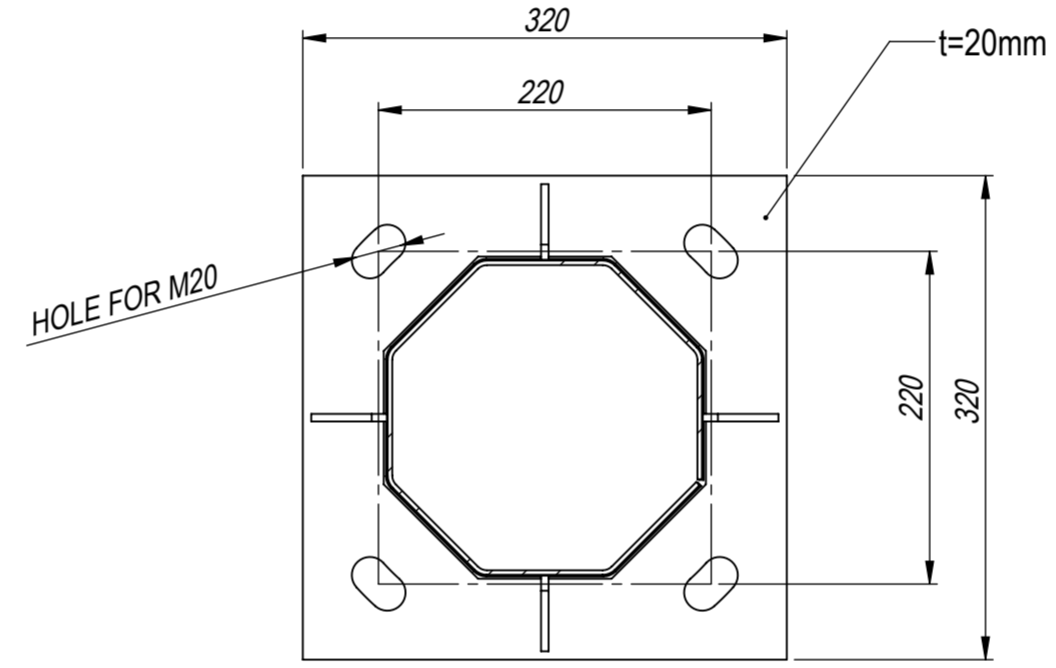

A-A (1:5)

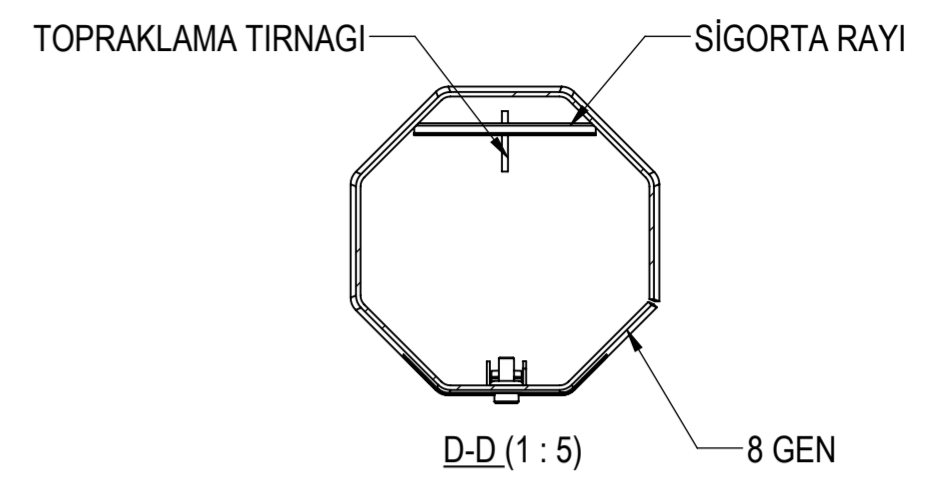

D-D (1:5)

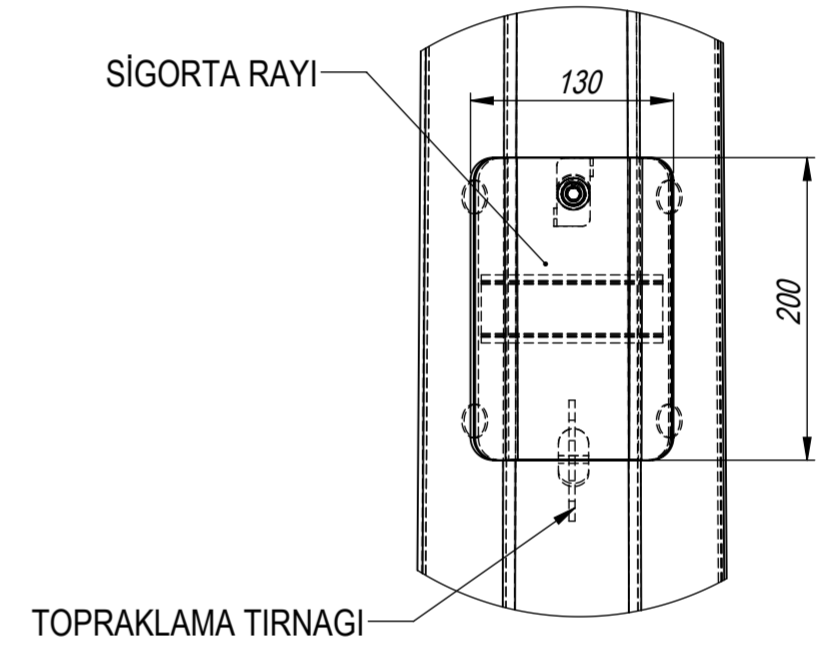

DETAIL B
SCALE: 1/5

ANCHOR SET: AC SET 4

REV.	TANIM DESCRIPTION	TARİH DATE	ONAY APPROVED
------	----------------------	---------------	------------------

GENEL NOTLAR
GENERAL NOTES
TÜM ÖLÇÜLER mm'DİR.
ALL DIMENSIONS ARE IN mm.
TÜM ÇELİK ELEMANLAR, CIVATA, SOMUN VE RONDDELALAR SICAK DALDIRMA GALVANİZDİR. (EN ISO 1461)
ALL STEEL ITEMS, BOLTS, NUTS & WASHERS TO BE HOT-DIP GALV. AS PER (EN ISO 1461)
TASARIM KRİTERLERİNE GÖRE CIVATALAR (ISO 898) 5.8 & 6.8 & 8.8 OLARAK KULLANILABİLİR.
BOLTS CAN BE USED AS (ISO 898) 5.8 & 6.8 & 8.8 ACCORDING TO DESIGN CRITERIA.

ADI - SOYADI NAME - SURNAME	TARİH DATE	İMZA SIGN	MALZEME MATERIAL	TASARIM NOTLARI DESIGN NOTES
ÇİZEN DRAWN BY NEKAPLAN	13.12.2019		GÖVDE SHAFT S235	TASARIM RÜZGAR HIZI DESIGN WIND SPEED 130 km/H
KONTROL CONTROL I.YUCEL	13.12.2019		FLANS FLANGE S235	GÜVENLİK KATSAYISI FACTOR OF SAFETY 1.67
ONAY APPROVAL K.CANBALOĞLU	13.12.2019		DİĞER OTHER S235	TASARIM STANDARTI DESIGN STANDART

**PAD2-120-30
OUTLINE**

SİPTEK. NO ORDER NUMBER	STANDART	REV 0
PAFTA NO DRAWING NUMBER	PAD2-120-30	
TARİH DATE	19.12.2019	
AGIRLIK WEIGHT		
BÖLÜM DEPARTMENT	POLİGON	
SHEET 1 OF 1	ÖLÇEK SCALE 1:100	A2

