

ALL RIGHTS RESERVED. REPRODUCTION OR ISSUE TO THIRTD PARTIES IN ANY FORM WHATSOEVER IS NOT PERMITTED WITHOUT WRITTEN AUTHORITY FROM THE PROPRIETORS.

HER HAKKI MAHFUZDUR. YAZILI İZİN OLMADAN DÖKÜMANLARIN HIÇ BİR KISMI KOPYA, KAYIT, BASIM VEYA DİĞER HERHANGİ BİR ŞEKİLDE ÇOGALTIYLAZ VE YAYINLANMAZ.

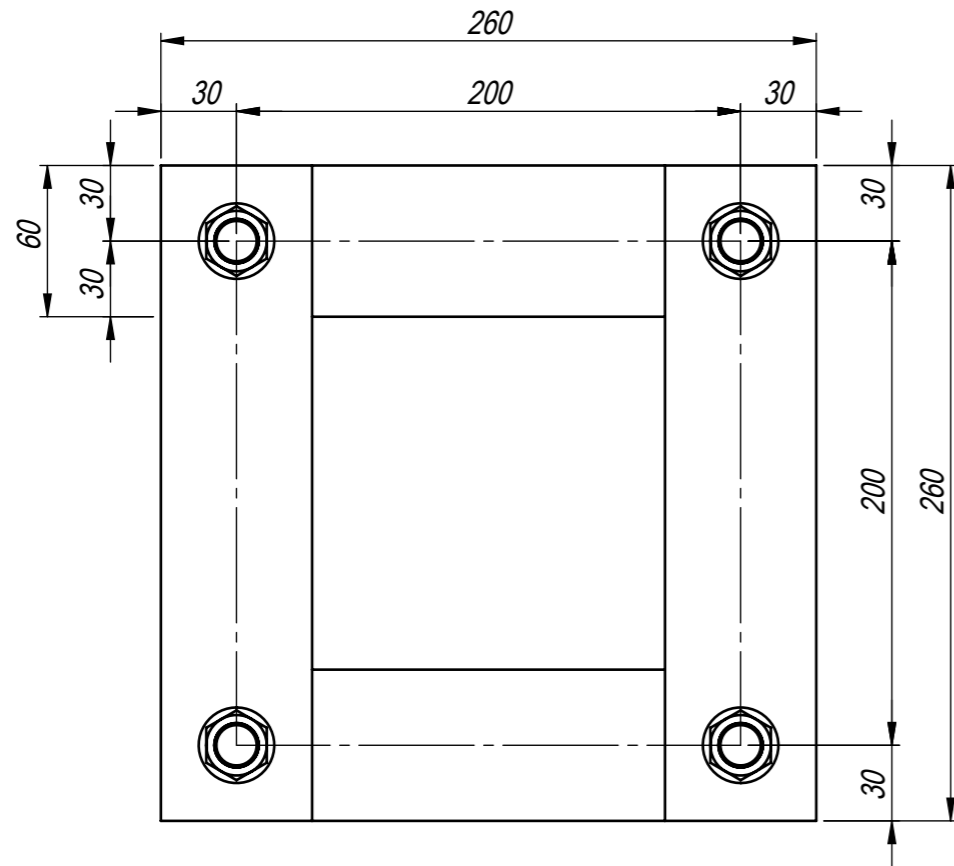

A-A (1:3)

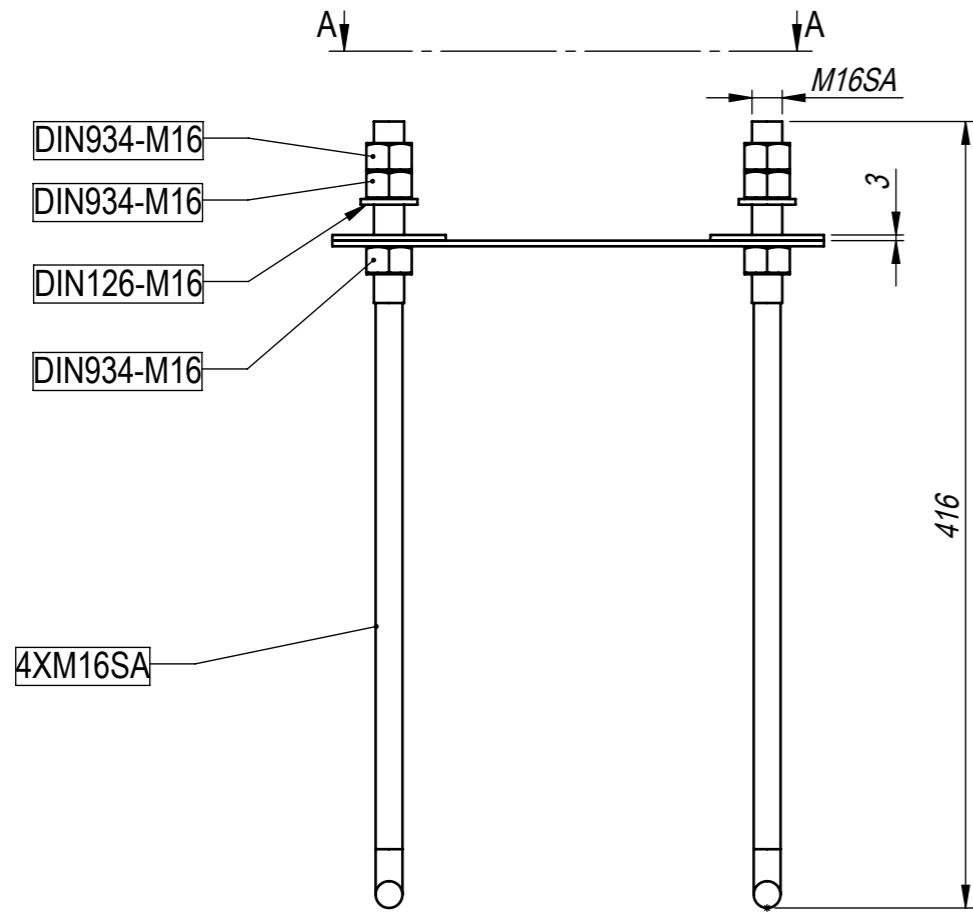
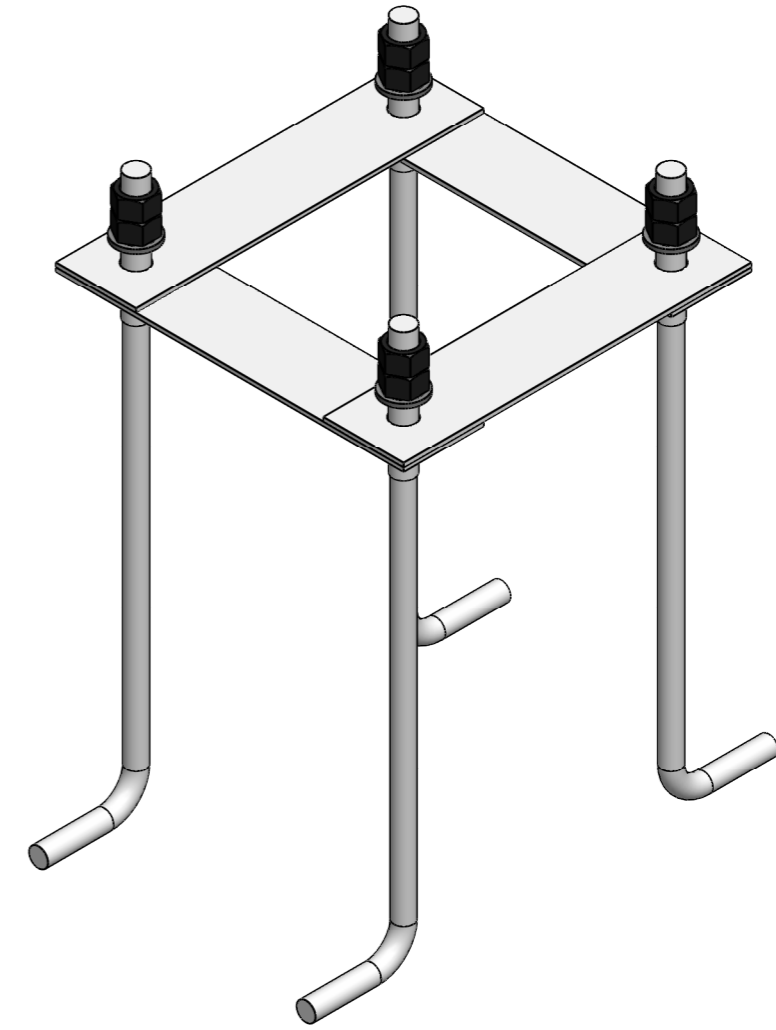

### REVİZYONLAR / REVISIONS

REV.	TANIM DESCRIPTION	TARİH DATE	ONAY APPROVED
------	----------------------	---------------	------------------

### GENEL NOTLAR GENERAL NOTES

TÜM ÖLÇÜLER mm'DİR.  
ALL DIMENSIONS ARE IN mm.  
TÜM ÇELİK ELEMANLAR, CIVATA, SOMUN VE RONDELALAR SICAK DALDIRMA GALVANİZDİR. (EN ISO 1461)  
ALL STEEL ITEMS, BOLTS, NUTS & WASHERS TO BE HOT-DIP GALVD. AS PER (EN ISO 1461)  
TASARIM KRİTERLERİNE GÖRE CIVATALAR (ISO 898) 5.8 & 6.8 & 8.8 OLARAK KULLANILABİLİR.  
BOLTS CAN BE USED AS (ISO 898) 5.8 & 6.8 & 8.8 ACCORDING TO DESIGN CRITERIA.

ADI - SOYADI NAME - SURNAME	TARİH DATE	İMZA SING	MALZEME MATERIAL	TASARIM NOTLARI DESIGN NOTES
ÇİZEN DRAWN BY <b>NEKAPLAN</b>	<b>5.03.2020</b>		GÖVDE SHAFT <b>S235</b>	TASARIM RÜZGAR HIZI DESIGN WIND SPEED
KONTROL CONTROL <b>I.YUCEL</b>	<b>5.03.2020</b>		FLANŞ FLANGE <b>S235</b>	GÜVENLİK KATSAYISI FACTOR OF SAFETY
ONAY APPROVAL <b>K.CANBALOĞLU</b>	<b>5.03.2020</b>		DİĞER OTHER <b>S235</b>	TASARIM STANDARDI DESIGN STANDART

### (PAD-SA-2019) - AC Set-3 OUTLINE

SİP/TEK.NO ORDER NUMBER	STANDART			REV 0
PAFTA NO DRAWING NUMBER	(PAD-SA-2019) - AC SET-3			
TARİH DATE	5.03.2020			
AĞIRLIK WEIGHT				
BÖLÜM DEPARTMENT	POLİGON	SHEET 1 OF 1	ÖLÇEK SCALE 1:5	A3

 MİTAŞ ENDÜSTRİ