

ASM NO.	NAME	QTY.	WEIGHT	T.WEIGHT
1	POWK-KBB1D	1	0.95106	0.95106
2	POWK-SB-1	1	0.89475	0.89475
3	POWK1-05-1	1	2.31961	2.31961

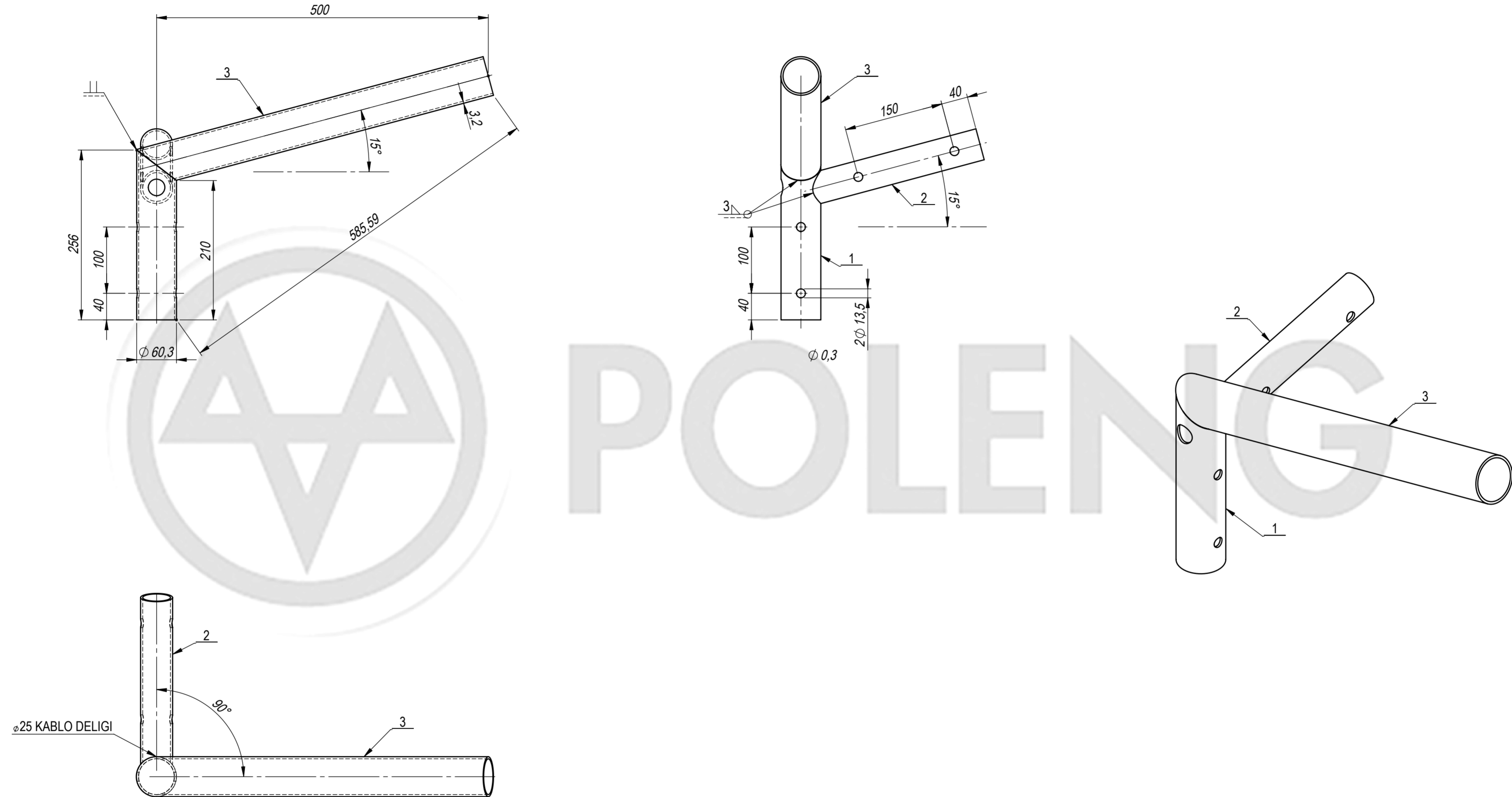

GENERAL NOTES / GENEL NOTLAR		MATERIAL / MALZEME		NAME / İSİM	SIGN / İMZA	DATE / TARİH	
* ALL DIMENSIONS ARE IN mm. TÜM ÖLÇÜLER mm'DİR.		SHAFT / GÖVDE	S235	DESIGN / HAZIRLAYAN	H.İNCE		
* ALL STEEL ITEMS,BOLTS,NUTS & WASHERS TO BE HOT-DIP GALVD.AS PER (EN ISO 1461)		FLANGE / FLANŞ	S235	DRAWN / CIZEN	hince		
TÜM ÇELİK ELEMANLAR,CIVATA, SOMUN VE RONDALALAR SICAK DALDIRMA GALVANİZDİR. (EN ISO 1461)		OTHER ACCESSORIES / DİĞER AKSESUARLAR	S235	CHECKED / KONTROL	İ.YÜCEL		
* BOLTS CAN BE USED AS (ISO 898) 5.8 & 6.8 & 8.8 ACCORDING TO DESIGN CRITERIA. TASARIM KRİTERLERİNE GÖRE CIVATALAR (ISO 898) 5.8 & 6.8 & 8.8 OLARAK KULLANILABİLİR.		APPROVED / ONAY	K.CANBALOĞLU				
				DESIGN NOTES / TASARIM NOTLARI		SIP/TEK.NO	STANDART
						PAFTA NO	PWR2-500-15D-90D-01
				DESIGN WIND SPEED / TASARIM RÜZGAR HIZI		TARİH	10.11.2017
				FACTOR OF SAFETY / GÜVENLİK KATSAYISI			
				DESIGN STANDART / TASARIM STANDARTI		SHEET 1 OF 1	SCALE 1:20 A2
						REV	A

REVISIONS / REVİZYONLAR			
REV.	DESCRIPTION / TANIM	DATE TARİH	APPROVED ONAY
A	FISRT ISSUE	10.11.2017	



MÜHENDİSLİK TASARIM DANIŞMANLIK
İNŞAAT SANAYİ TİCARET A.Ş.
İhsan Doğramacı Bulvarı Üniversiteler Mah. 37/4 TEKNOKENT
Tel : 0 (312) 296 23 23
info@poleng.com.tr