

ASM NO.	NAME	QUALTY	MATERIAL	LENGHT	WIDTH	QTY.	WEIGHT	T.WEIGHT
1	ADK1-500-15D	1.0037 (S235JR)	PWD60.3X3.2	541	0	1	2.31768	2.31768
2	KNS3-ALT-15B	1.0037 (S235JR)	PWD60.3X3.2	256	0	1	0.99219	0.99219
3	KNS-KOL-15D	1.0037 (S235JR)	PWD48.3X3.2	265.5	0	2	0.89046	1.78092

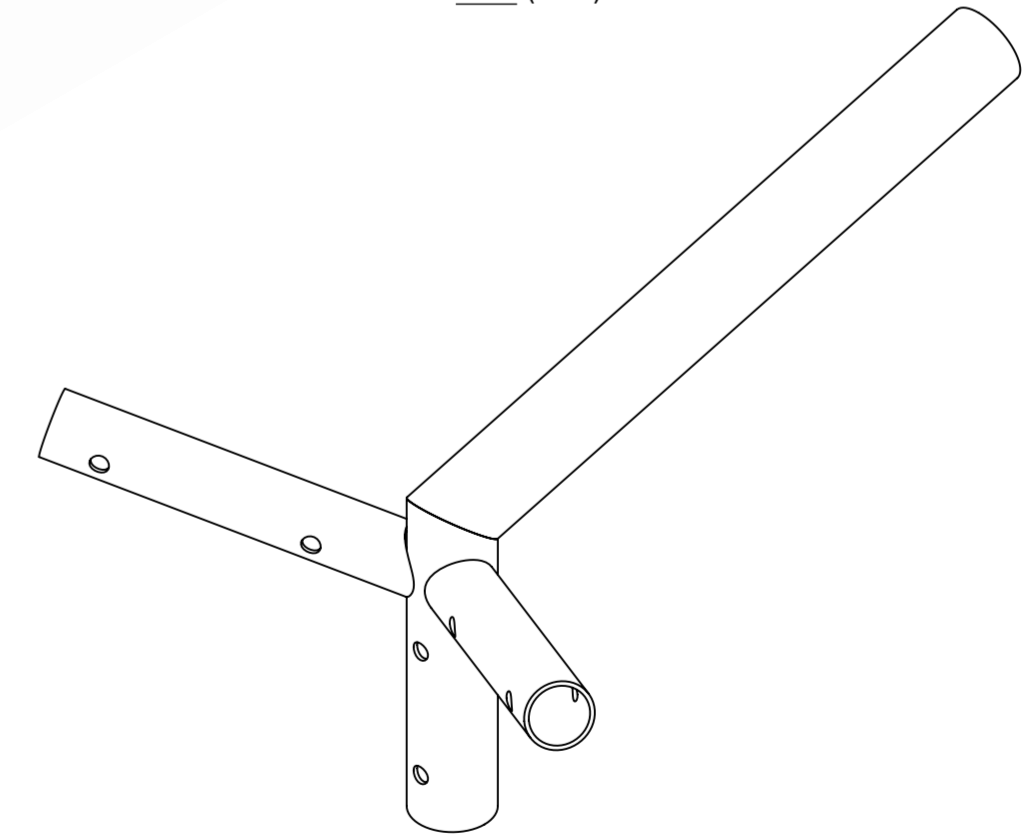
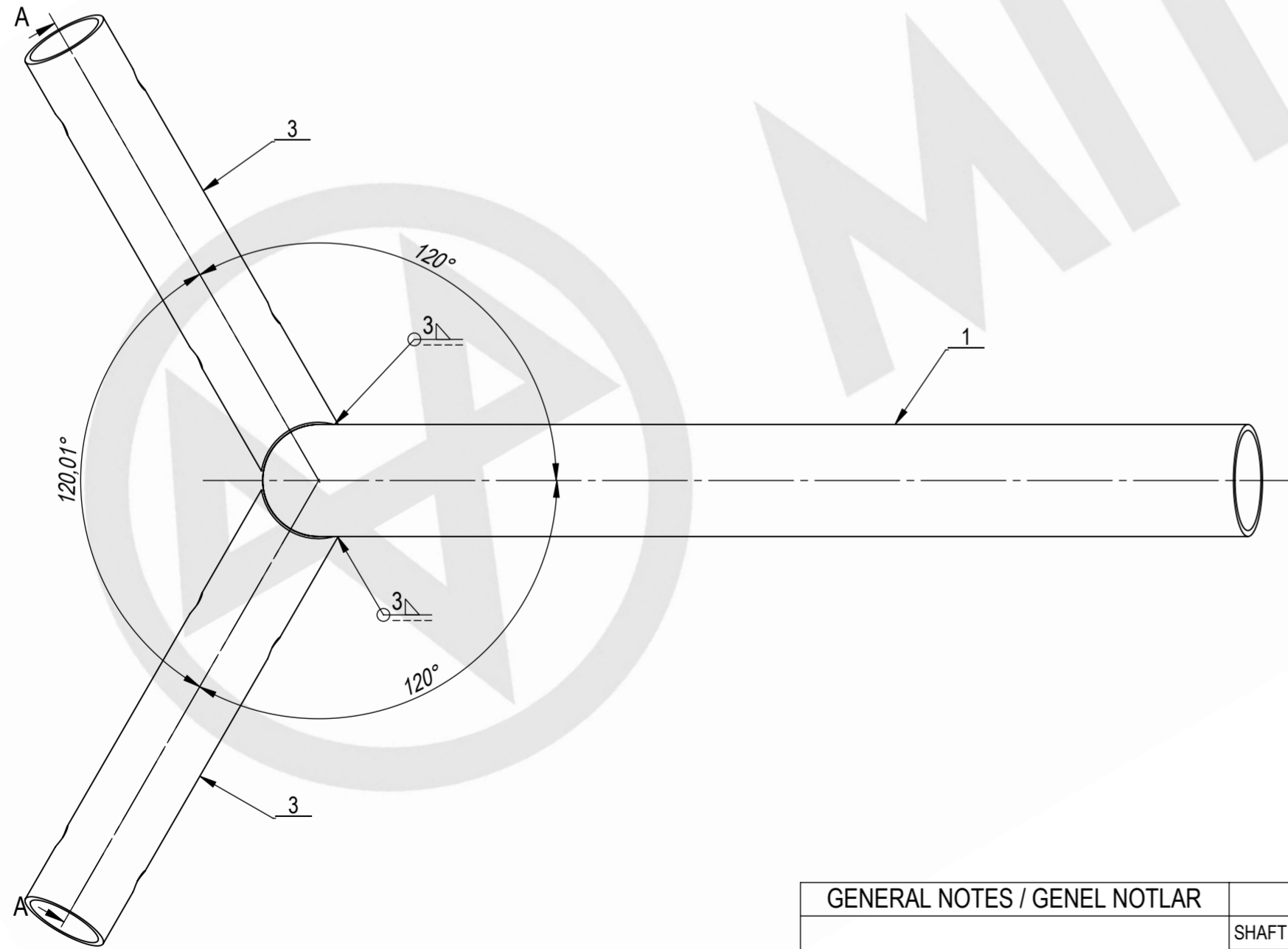
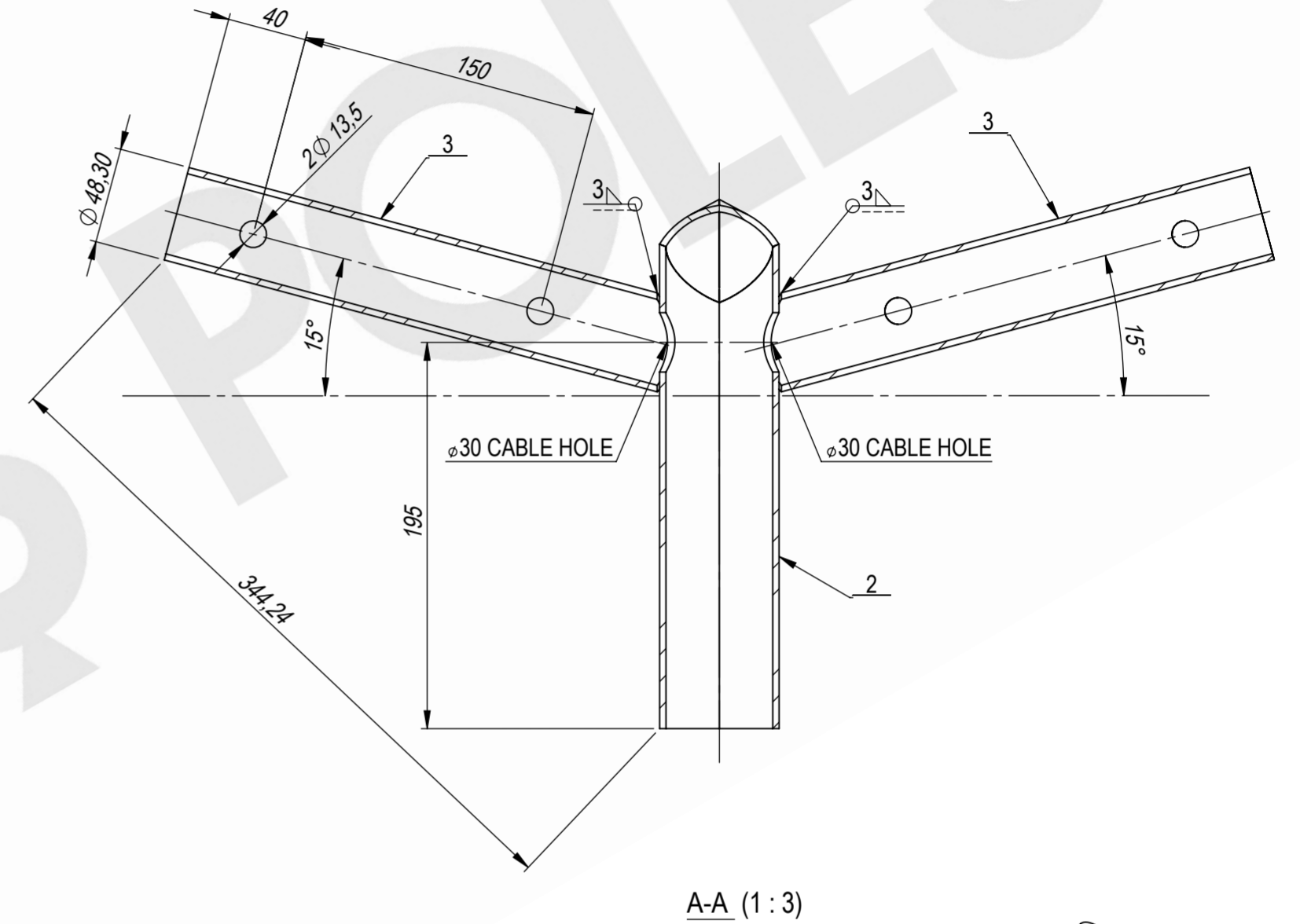
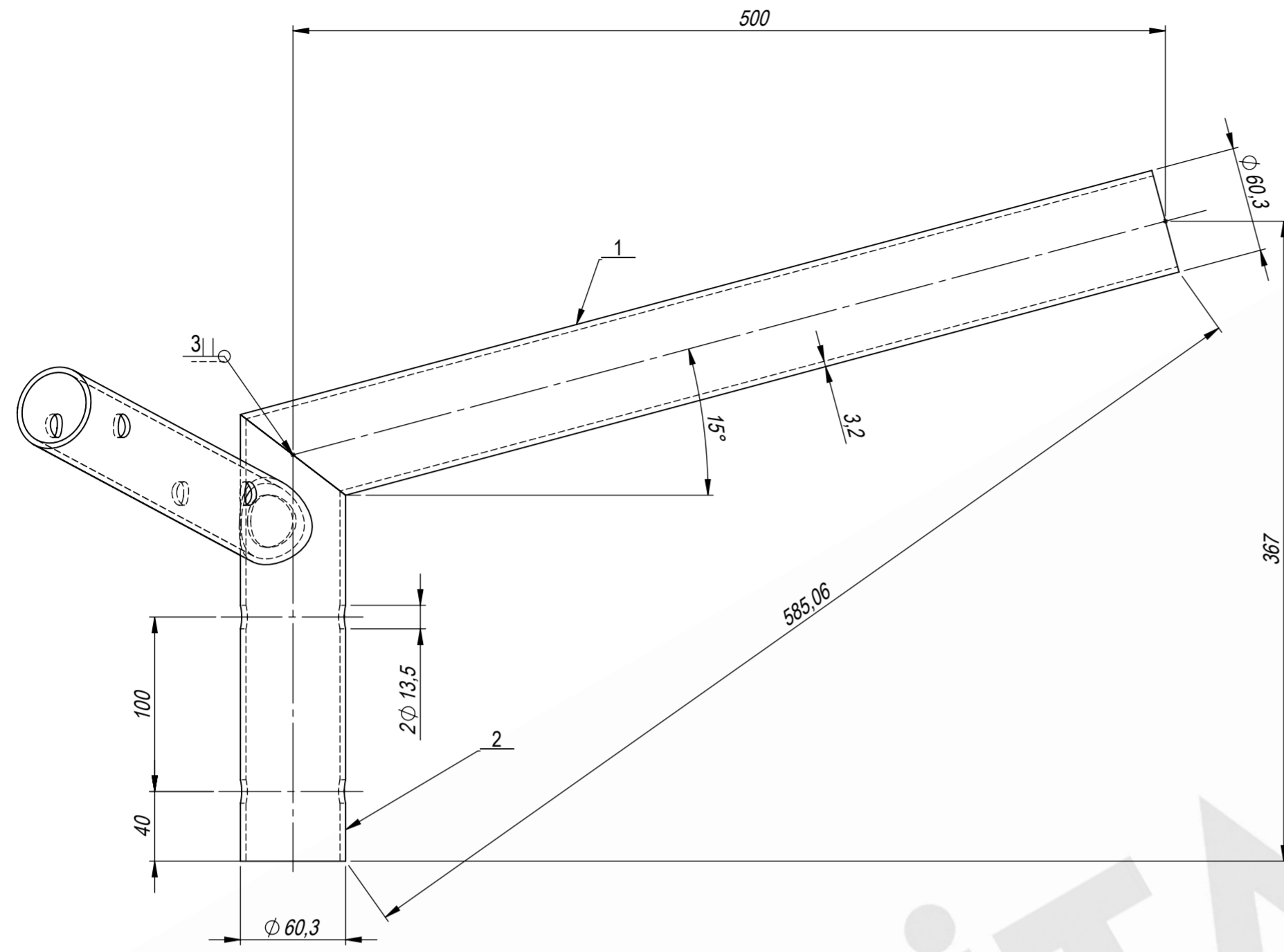

GENERAL NOTES / GENEL NOTLAR		MATERIAL / MALZEME		NAME / İSİM	SIGN / İMZA	DATE / TARİH
* ALL DIMENSIONS ARE IN mm. TÜM ÖLÇÜLER mm'DİR.		SHAFT / GÖVDE	S235	DESIGN / HAZIRLAYAN	K.CANBALOĞLU	24.1.2017
* ALL STEEL ITEMS,BOLTS,NUTS & WASHERS TO BE HOT-DIP GALVD.AS PER (EN ISO 1461)		FLANGE / FLANŞ	S235	DRAWN / ÇİZEN	hince	24.1.2017
TÜM ÇELİK ELEMANLAR,CIVATA, SOMUN VE RONDELALAR SICAK DALDIRMA GALVANİZDİR. (EN ISO 1461)		OTHER ACCESSORIES / DİĞER AKSESUARLAR	S235	CHECKED / KONTROL	M.KARAARSLAN	24.1.2017
* BOLTS CAN BE USED AS (ISO 898) 5.8 & 6.8 & 8.8 ACCORDING TO DESIGN CRITERIA. TASARIM KRİTERLERİNE GÖRE CIVATALAR (ISO 898) 5.8 & 6.8 & 8.8 OLARAK KULLANILABİLİR.				APPROVED / ONAY	K.CANBALOĞLU	24.1.2017
				DESIGN NOTES / TASARIM NOTLARI	PAFTA NO	TDS3-500-15D-DK-60
				DESIGN WIND SPEED / TASARIM RÜZGAR HIZI	TARİH	24.1.2017
				FACTOR OF SAFETY / GÜVENLİK KATSAYISI		
				DESIGN STANDART / TASARIM STANDARTI	SHEET 1 OF 1	SCALE 1:10 A2

REVISIONS / REVİZYONLAR			
REV.	DESCRIPTION / TANIM	DATE TARİH	APPROVED ONAY
A	FIRST ISSUE	24.1.2017	

**P2-KONS.KG149**  
**TDS3-500-15D-DK-60**  
**KAYNAK RESMİ**



MİTAŞ POLİGON DEMİR ÇELİK A.Ş.  
Eski Güvercinlik Yolu No.113 Gazı 06560 ANKARA  
Tel:+90.312 296 20 00 Fax:+90.212 310 46 36  
Kızılbey Y.D.9220658412 www.mitaspole.com