

ALL RIGHTS RESERVED. REPRODUCTION OR ISSUE TO THIRD PARTIES IN ANY FORM WHATSOEVER IS NOT PERMITTED WITHOUT WRITTEN AUTHORITY FROM THE PROPRIETORS.

HER HAKKI MAHFUZDUR. YAZILI IZIN OLMADAN DOKÜMANLARIN HIÇ BİR KISMI KOPYA, KAYIT, BASIM VEYA DİĞER HERHANGİ BİR ŞEKİLDE ÇOĞALTILMAZ VE YAYINLANMAZ.

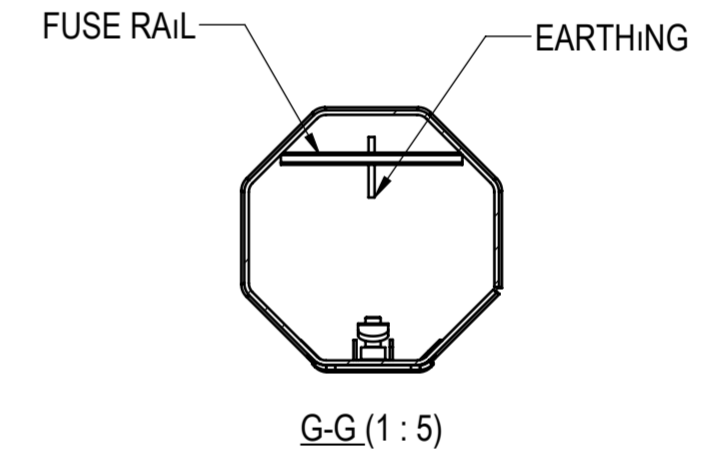
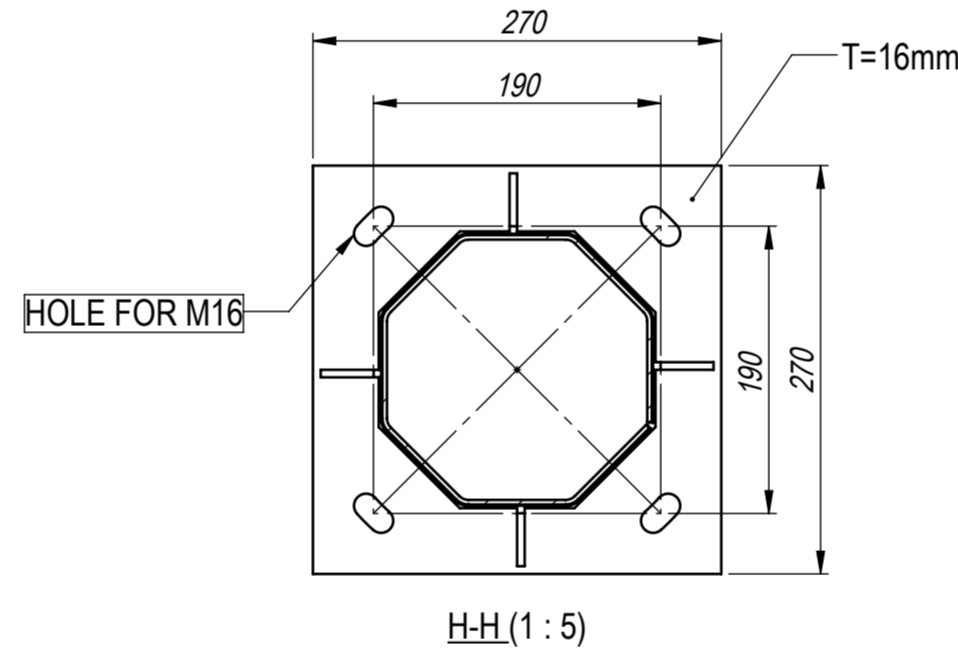
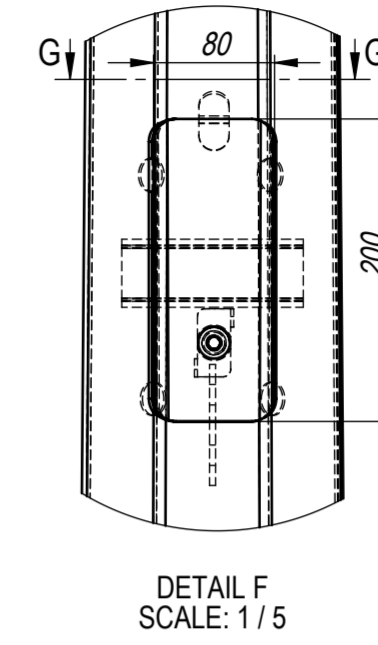
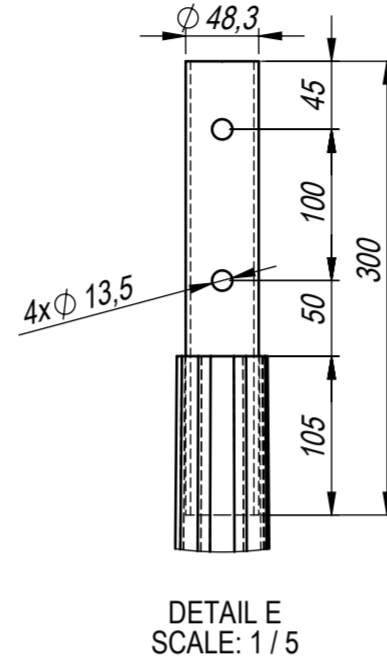
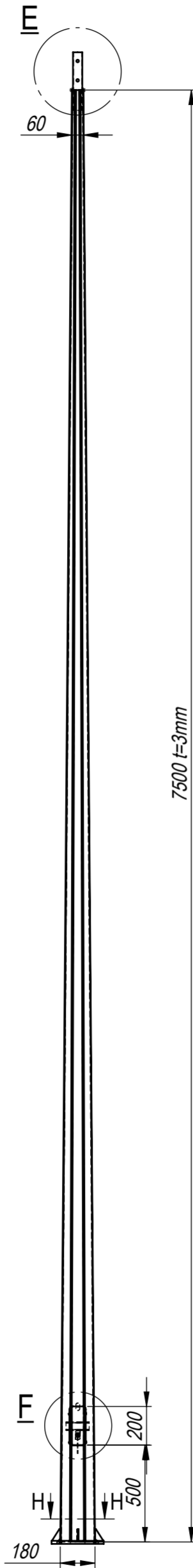
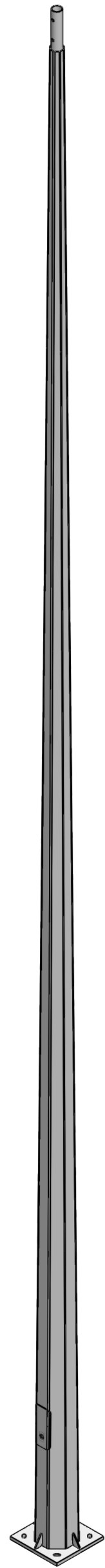

ANCHOR SET: AC SET 7

REVİZYONLAR / REVISIONS						
REV.	TANIM DESCRIPTION	TARİH DATE	İMZA SIGN	ONAY APPROVED		
GENEL NOTLAR GENERAL NOTES						
TÜM ÖLÇÜLER mm'DİR. ALL DIMENSIONS ARE IN mm.						
TÜM ÇELİK ELEMANLAR, CIVATA, SOMUN VE RONDDELALAR SICAK DALDIRMA GALVANİZDİR. (EN ISO 1461) ALL STEEL ITEMS, BOLTS, NUTS & WASHERS TO BE HOT-DIP GALV. AS PER (EN ISO 1461)						
TASARIM KRİTERLERİNE GÖRE CIVATALAR (ISO 898) 5.8 & 6.8 & 8.8 OLARAK KULLANILABİLİR. BOLTS CAN BE USED AS (ISO 898) 5.8 & 6.8 & 8.8 ACCORDING TO DESIGN CRITERIA.						
ADİ - SOYADI NAME - SURNAME	TARİH DATE	İMZA SIGN	MALZEME MATERIAL	TASARIM NOTLARI DESIGN NOTES		
CİZEN DRAWN BY	NEKAPLAN	21.01.2020	GÖVDE SHAFT	S235	TASARIM RÜZGAR HIZI DESIGN WIND SPEED	130 km/H
KONTROL CONTROL	I.YUCEL	21.01.2020	FLANŞ FLANGE	S235	GÜVENLİK KATSAYISI FACTOR OF SAFETY	1.67
ONAY APPROVAL	K.CANBALOGLU	21.01.2020	DİĞER OTHER	S235	TASARIM STANDARTI DESIGN STANDART	

PAD4-80-20
OUTLINE

SİPTEK.NO ORDER NUMBER	STANDART					
PAFTA NO DRAWING NUMBER	PAD4-80-20					
TARİH DATE	22.01.2020					
AĞIRLIK WEIGHT						
BÖLÜM DEPARTMENT	POLİGON	SHEET 1 OF 1	ÖLÇEK SCALE	1:50	A2	REV 0

