

H 1500	GWN1101XB	GWN1101CF	GWN1101CP
	GWN1111XB	GWN1111CF	GWN1111CP
H 1800			

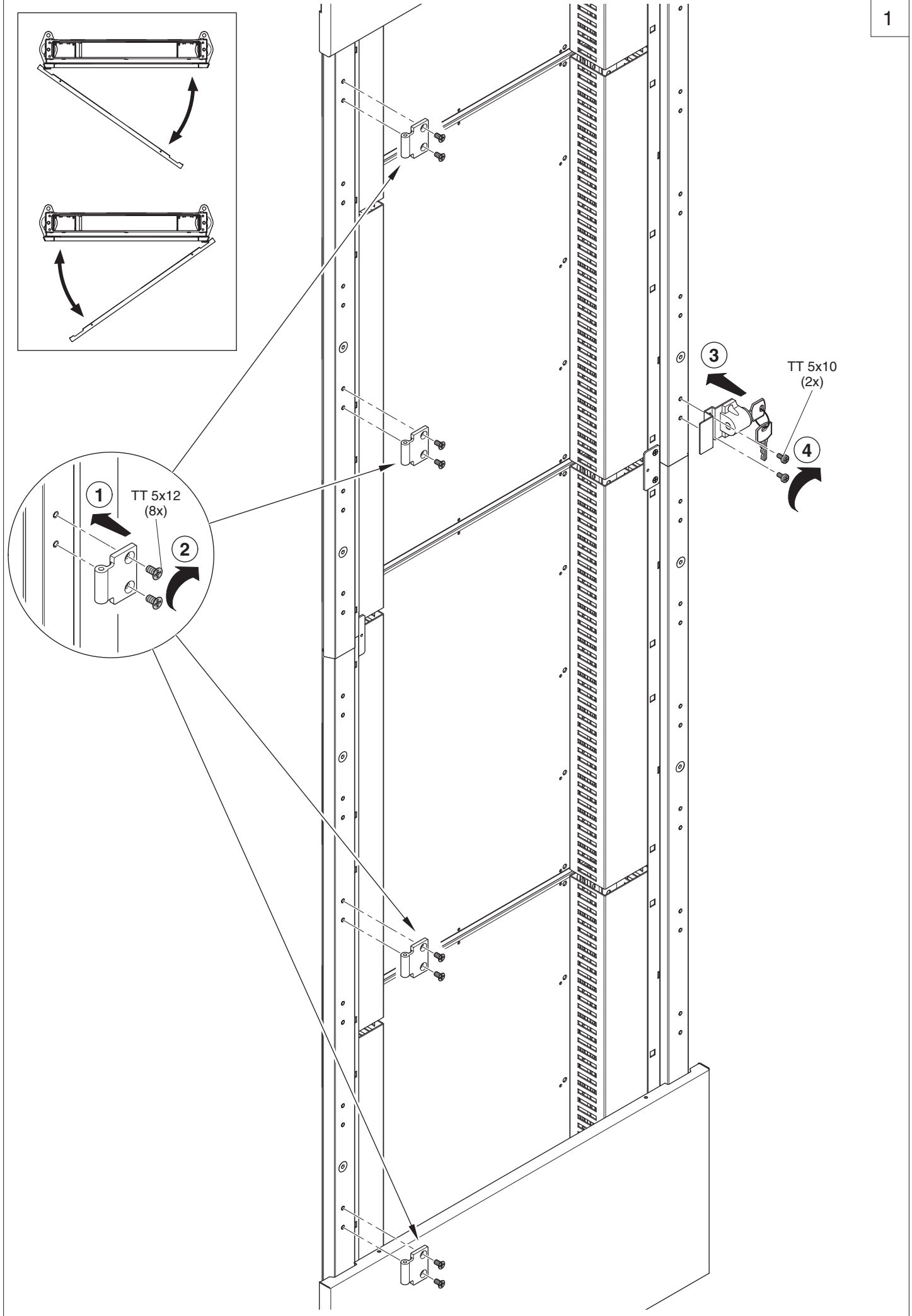

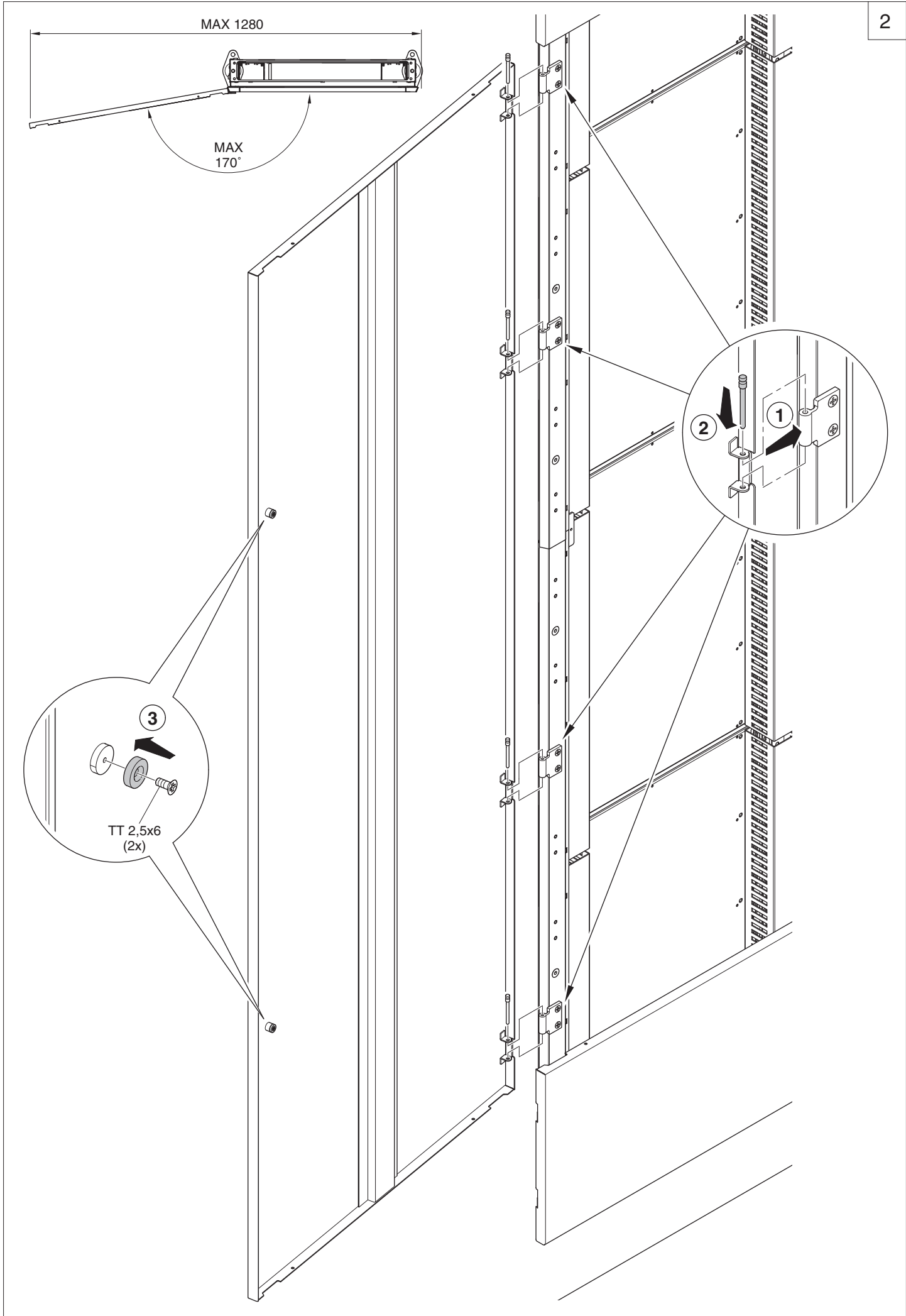

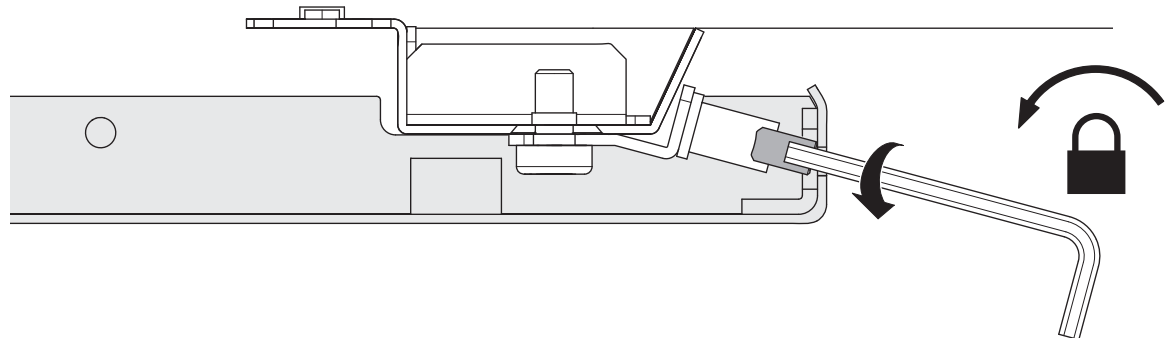

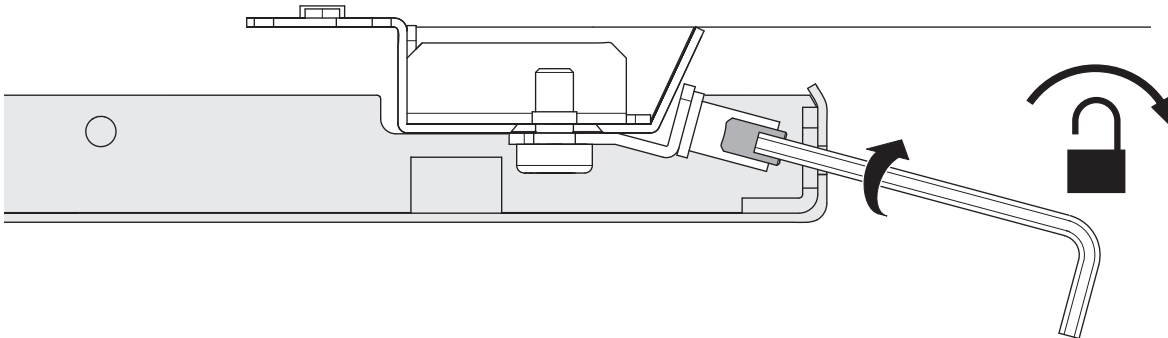
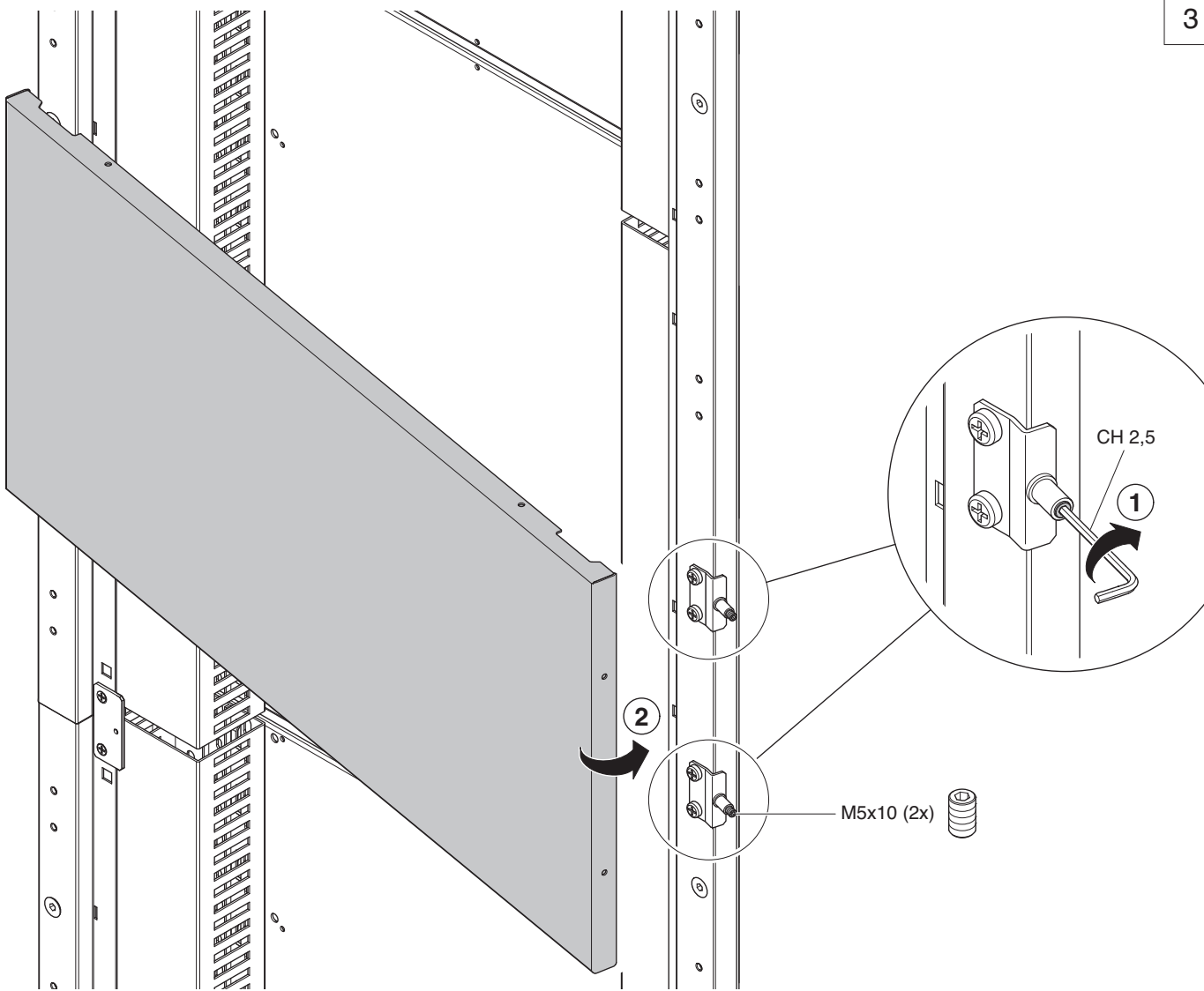
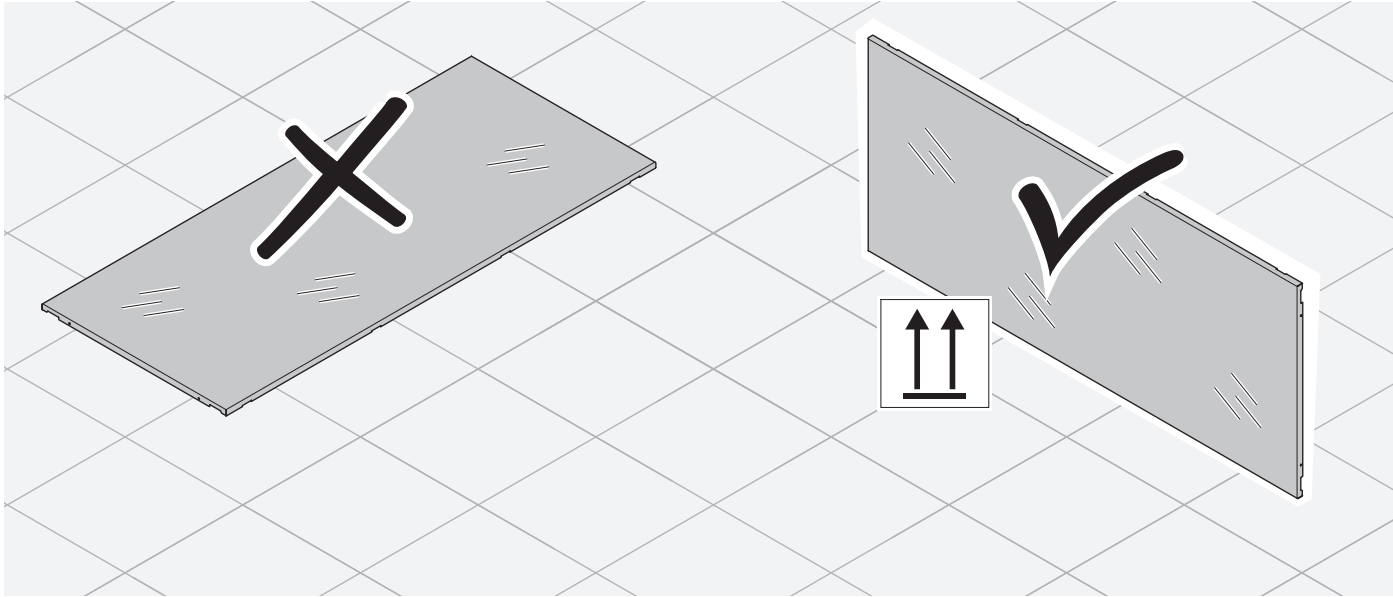
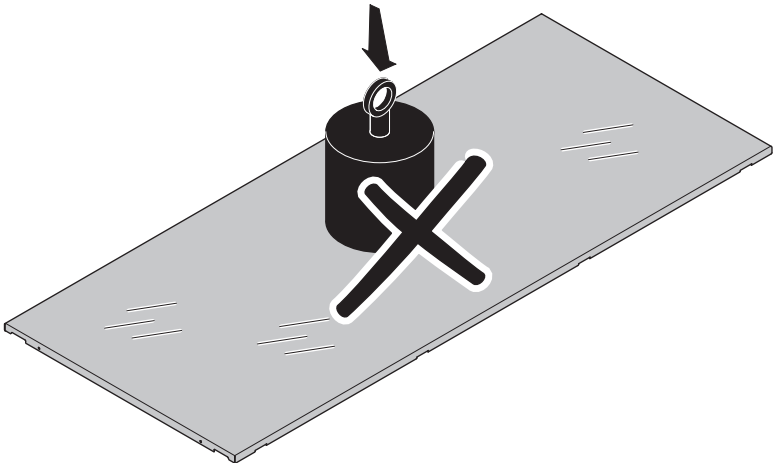

IP4

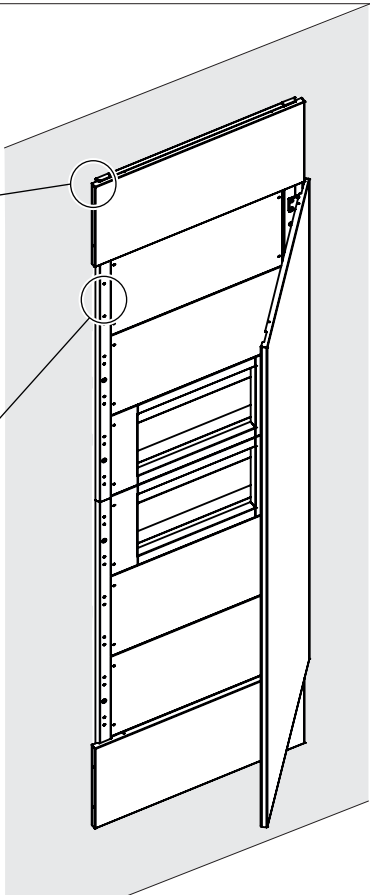
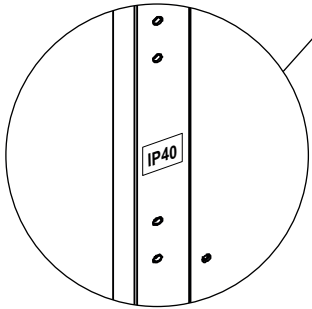
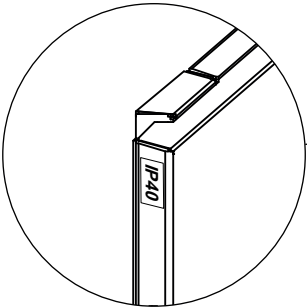

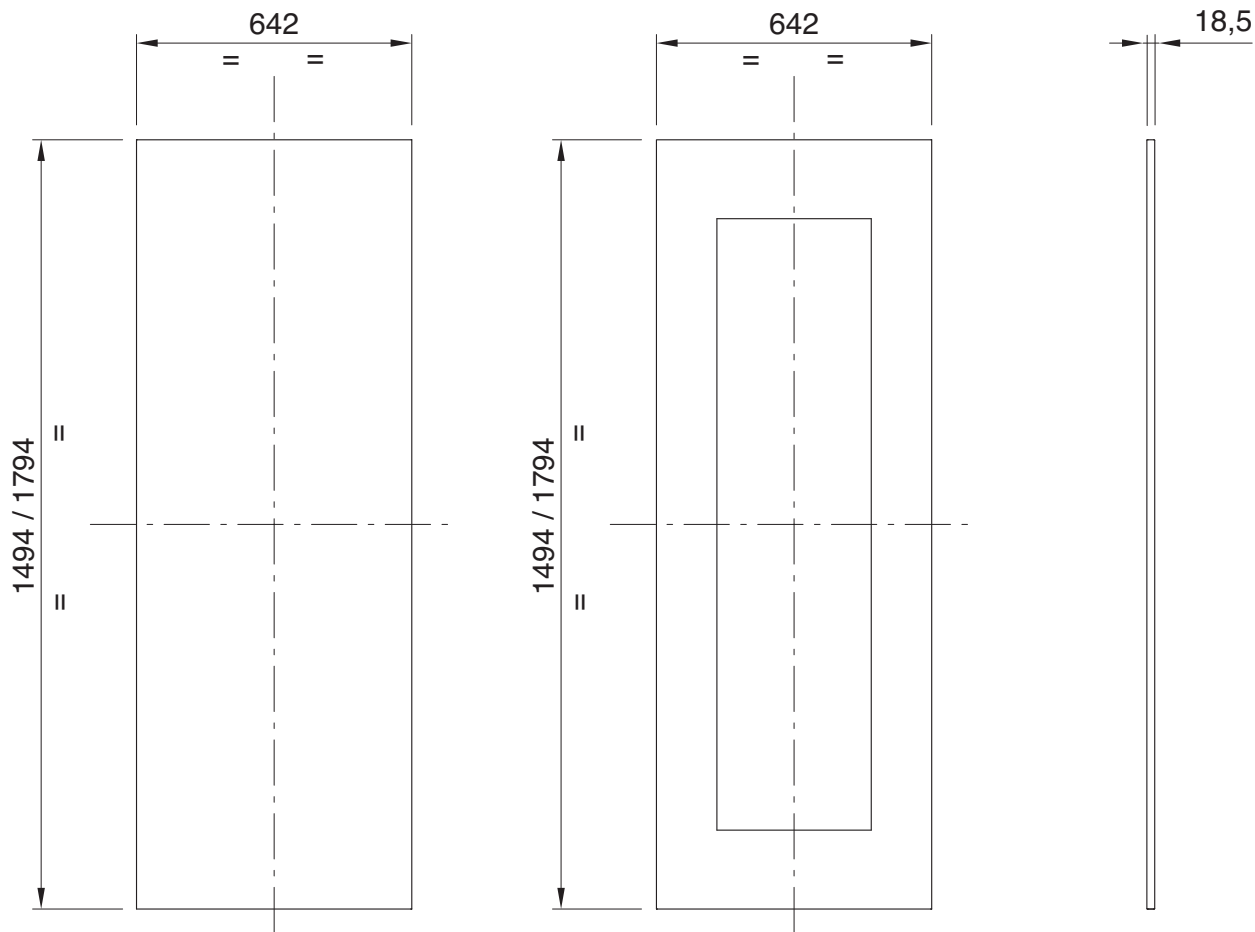

Ai sensi dell'articolo R2 comma 6 della Decisione 768/2008/CE si informa che responsabile dell'immissione del prodotto sul mercato Comunitario è:
According to article R2 paragraph 6 of the Decision 768/2008/EC, the responsible for placing the apparatus on the Community market is:
GEWISS S.p.A Via A. Volta, 1 - 24069 Cenate Sotto (BG) Italy Tel: +39 035 946 111 Fax: +39 035 945 270 E-mail: qualitymarks@gewiss.com



+39 035 946 111
8.30 - 12.30 / 14.00 - 18.00
lunedì + venerdì - monday + friday



+39 035 946 260



sat@gewiss.com
www.gewiss.com