

Wide range of switches, energy sockets (compliant with national and international standards), data sockets, devices for the management of climate control, comfort, technical alarms signalling, emergency lighting. The Chorus modular devices are available in five colors, glossy white, satin white, natural beige, satin black, painted titanium and in different modularities, 1/2, 1, 2 and 3 modules. Thanks to the frame supports for rectangular, square and round boxes, the devices allow you to create endless combinations with the range of Chorus plates.

Category	Badge switch	Colour	Satin White
Description	1P NA - 16 AX illuminable	Standard	EN 60669-1
Resistance at test voltage	2000 V at 50 Hz for 1 minute	Rated power of 230V LED lamps	200 W
Insulation resistance	> 5 MOhm	Wiring terminals	With screw
For badge card max. width	54 mm	Prolonged operation switch (no.of position changes)	40.000 at In 250 V ac cosØ=0,6
Thermo-pressure with ball	125 °C	Glow Wire Test	850 °C
Terminal grip on cable traction	> 50 N	Terminal tightening capacity stranded cables (mm2)	min. 0,75 - max. 2x4
Terminal tightening capacity solid cables (mm2)	min. 0,5 - max. 2x2,5	No. Chorus modules	2
Electrocod	0134		

DIMENSIONAL

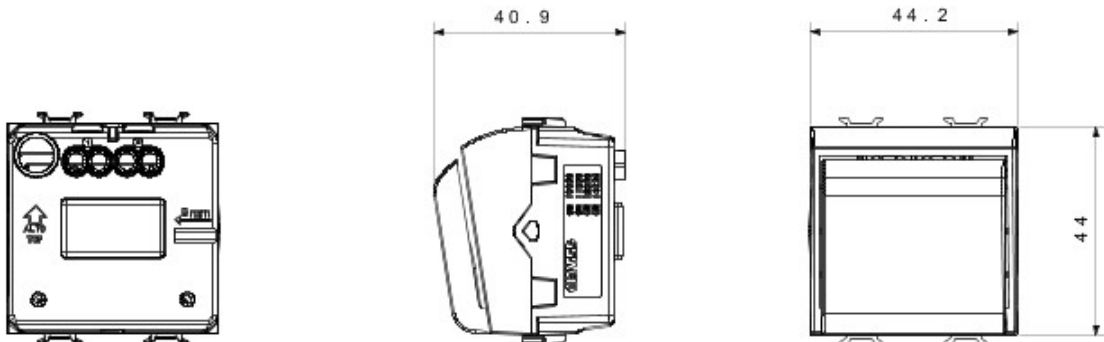

TECHNICAL SYMBOLOGY



STANDARDS/APPROVALS

