

Recessed LED DALI panel

Recessed LED DALI dimmable panel UGR<19 with adjustable color temperature of 3000K, 3500K or 4000K by switch directly on luminaire. Gentle, soft and glare-free lighting for office applications with opal diffuser made of TpB rated PET for fully homogenous illumination and aluminium frame. TRIDONIC Excite driver (87500923) offering dimming range 1 to 100% via DALI-2 and switchDIM. DC level adjustable. Mains frequency 0/50/60 Hz. CorridorFUNCTION. Luminaire input power: 34 W. Lifetime of 50.000h before luminous flux is reduced to 80 % of the initial value. Chromaticity tolerance (initial MacAdam): 4. Total luminous flux: 3750 lm, Luminaire efficacy: 110 lm/W (4000K), Luminaire efficacy: 110 lm/W (4000K). Colour rendering Ra > 80, Tool-free installation (piano key terminal for up to 2.5 mm² wires). External connector box enabling loop-in loop-out wiring. Suitable for emergency escape lighting systems acc. to EN 50172. Flicker free. Suitable for lay-in installation, suspension and surface mounting. Dimensions: 596 x 596 x 60 mm weight: 2.23 kg

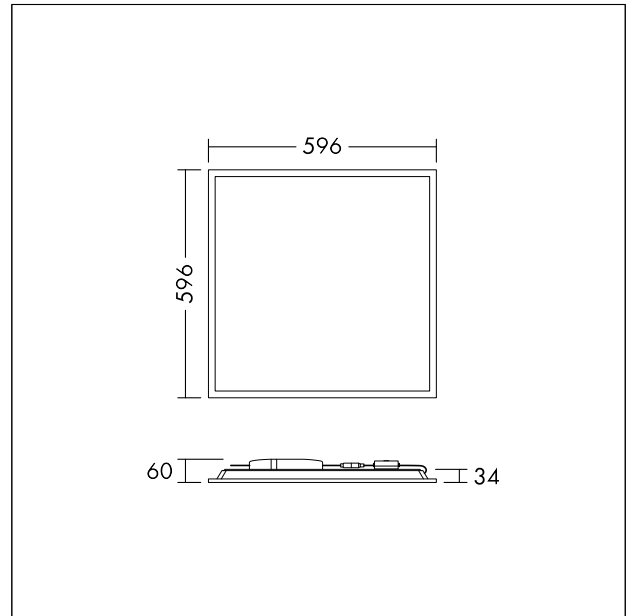

TE_ANNAVARIO_F_600_persp.jpg



TE_ANNAVARIO_M_596.wmf

Light Distribution

STD - standard

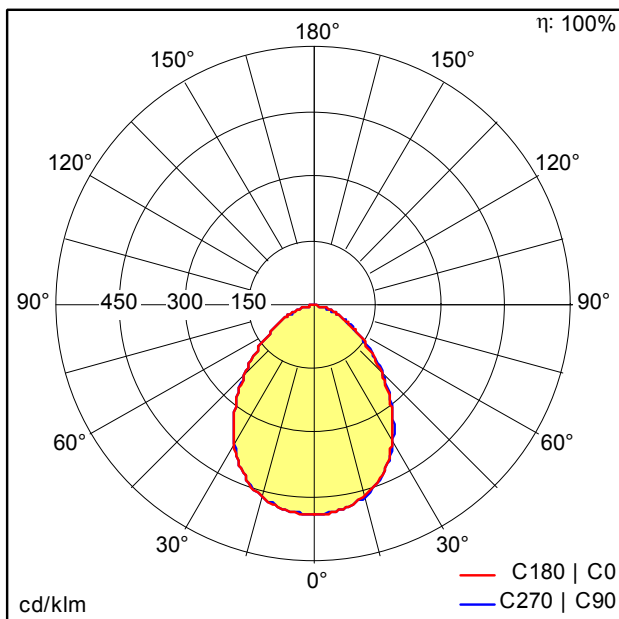

TE_ANNA_VARIO_Q596_3000_840.ltd

- Light Source: LED
- Luminaire luminous flux*: 3754 lm
- Luminaire efficacy*: 110 lm/W
- Colour Rendering Index min.: 80
- Correlated colour temperature: 3000-4000 Kelvin
- Chromaticity tolerance (initial MacAdam): 4
- Rated median useful life*: L80 50000h at 25°C
- Ballast: 1x HFI* Tridonic LC EXC
- Luminaire input power*: 34 W Power factor = 0.95
- Dimming: HFIX dimmable to 1%

All values marked with an * are rated values. Luminous flux and connected electrical load are subject to an initial tolerance of +/- 10%. Unless stated otherwise, the values apply to an ambient temperature of 25°C.