

					ta: -20°C ...+40°C		
1004686	220V-240V ~50/60Hz	26W	2700 lm	3000K	CRI>90	41 x 5,6 x 10,5 cm	1,14 kg
1004687			3100 lm	4000K			
1004688							
1004689							

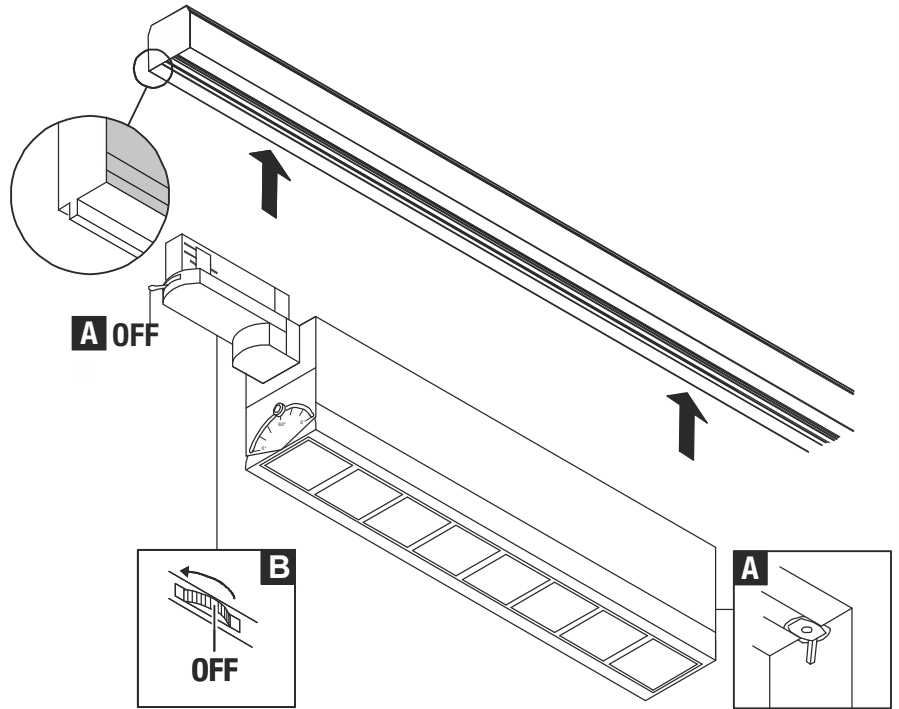

- DE** BETRIEBSANLEITUNG TEIL A Leuchte für SLV / Eutrac 3- Phasen Stromschienensystem
- EN** INSTRUCTION MANUAL PART A Luminaire for SLV / Eutrac 3-Phase Track System
- FR** MODE D'EMPLOI PARTIE A Luminaire pour système de rail 3 phases SLV / Eutrac
- ES** MANUAL DE INSTRUCCIONES PARTE A Luminaria para sistema de carril SLV/Eutrac de 3 fases
- IT** ISTRUZIONI PER L'USO PARTE A Lampada per sistema di binari elettrificati trifase SLV / Eutrac
- NL** GEBRUIKSAANWIJZING DEEL A Armatuur voor SLV / Eutrac 3-fasen spanningsrailsysteem
- DA** DRIFTSVEJLEDNING PART A Lampe til SLV / Eutrac 3-faset strømskinnesystem
- PL** INSTRUKCJA OBSŁUGI CZĘŚĆ A Oprawa do 3-fazowego systemu szynowego SLV / Eutrac
- RU** ИНСТРУКЦИЯ ПО ЭКСПЛУАТАЦИИ ЧАСТЬ А Светильник для 3-фазной осветительной трековой системы SLV / Eutrac
- SV** BRUKSANVISNING DEL A Armatur för SLV / Eutrac 3-fas kontaktskenesystem
- TR** KULLANMA KILAVUZU BÖLÜM A SLV / Eutrac 3 fazlı lamba Akım hattı sistemi
- HU** HASZNÁLATI UTASÍTÁS, A. RÉSZ Lámpák 3 fázisú SLV / Eutrac áramsín-rendszerhez

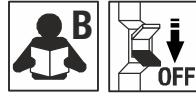

1004686
...87
...88
...89

