

SLV GmbH

BETRIEBSANLEITUNG FÜR
BODENEINBAULEUCHTE

OPERATING MANUAL FOR
RECESSED GROUND LUMINAIRE

MODE D'EMPLOI POUR
ENCASTRÉ DANS LE SOL

INSTRUCCIONES DE SERVICIO PARA
LUMINARIA EMPOTRAR EXTERIOR

ISTRUZIONI DI FUNZIONAMENTO PER
LAMPADA DA INCASSO

GEbruikshandleiding voor
GRONDINBOUWLAMP

INSTRUKTIONSVEJLEDNING FOR
NEDGRAVNINGSLAMPE

INSTRUKCJA OBSŁUGI DLA
LAMPY DO MONTAŻU W ZIEMI

РУКОВОДСТВО ПО ЭКСПЛУАТАЦИИ
СВЕТИЛЬНИК ДЛЯ МОНТАЖА В ПОЛУ

BRUKSANVISNING FÖR
MARKLAMPAN FÖR INFÄLLD MONTERING

ZEMIN ALTI LAMBA
IÇIN KULLANMA KILAVUZU

KEZELÉSI ÚTMUTATÓ
PADLÓBA SÜLLYESZTETT LÁMPATEST



229383

220V-240V
~50/60Hz



Power
34W



IP65
IP67

LED,
1620lm, 3000K,
CRI>80

25,5 x 25,5 x 14,5
cm

6,00
kg

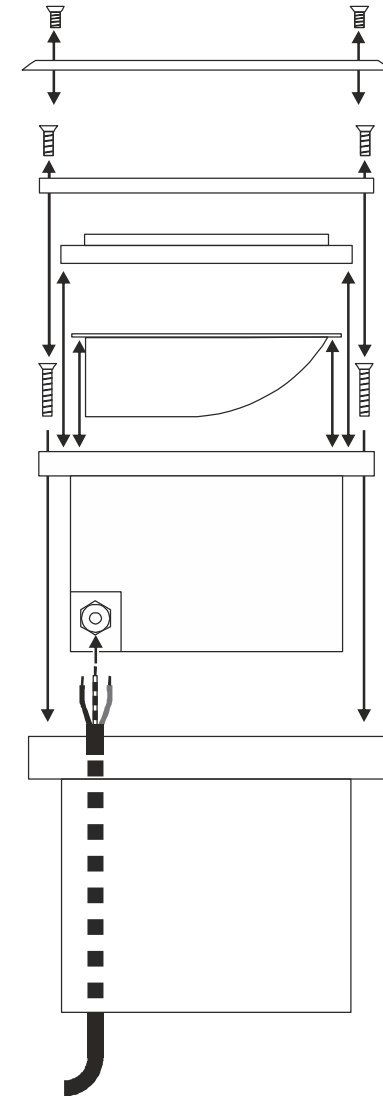
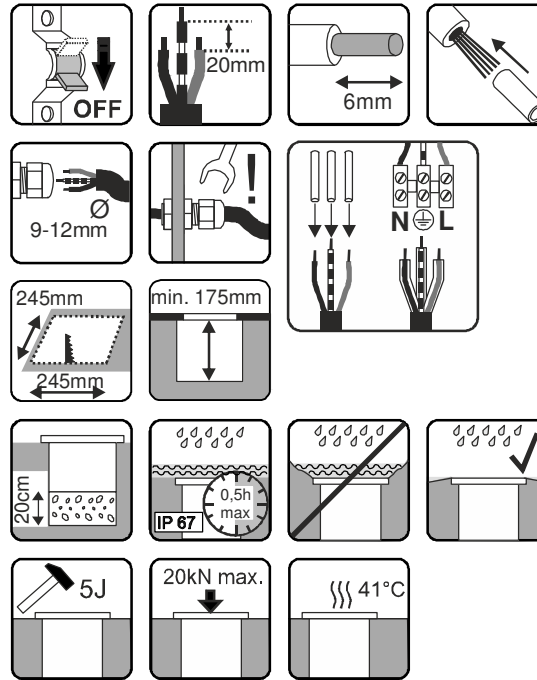

art.-no. 229383 170703 © SLV GmbH, Daimlerstr. 21-23, 52531 Übach-Palenberg, Germany, Tel. +49 (0)2451 4833-0 Technische Änderungen vorbehalten. Technical Details are subject to change. Les détails techniques sont sujet à des changements. Nos reservamos el derecho a modificaciones técnicas. Modifiche tecniche riservate. Behoudens technische wijzigingen. Ret til tekniske ændringer forbeholdes. Zmiany techniczne zastrzeżone. Сохраняется право на внесение технических изменений. Tekniska ändringar kan förekomma. Teknik deðişiklik yapma hakkı saklıdır. A technikai részletek termékenként változhatnak. Made in China.

ENGLISH

OPERATING MANUAL FOR RECESSED GROUND LUMINAIRE 229383

Read this short manual carefully and keep it accessible for further reference!

SAFETY MESSAGES

Disregard of the safety messages may lead to danger of life, burning or fire!

- Installation, mounting or works on the electrical connection may only be carried out by an approved electrician.
- The product may not be modified or converted.
- Do not hang or fasten anything on the product, especially no decoration.
- Do not cover the product - provide free air circulation.
- The luminaire may only be operated with a complete and intact protection glass.
- In case of a malfunction you may NOT touch the product or operate it further. Disconnect the product from the power supply by an external switch or by the fuse.

A malfunction exists when:

- visible damages appear.
- the product does not work properly (e.g. flickering).
- smoke, steam or crackling sounds appear.
- smell of burning is recognisable.
- an overheating is recognisable (e.g. by discolouration of adjacent surfaces).

Operate the product only after maintenance and examination by an approved electrician!

- This product is not intended to be used by children. Ensure that children do not suffer any harm e.g. by burns from hot surfaces or by electrical shock.

Additional safety messages are indicated by this symbol: .

USE AS DIRECTED

This product serves exclusively lighting purposes and may:

- only be used with a voltage of 230V ~50Hz.
- only be installed according to safety class I (one).
- only be operated when firmly mounted on a stable, even and tilt-fixed surface.
- only be operated on normally or not flammable surfaces.
- not be exposed to strong mechanical loads or to strong contamination.

MAINTENANCE AND CARE

Light source

- The light source of this luminaire may only be replaced by the manufacturer, an authorized service technician or a comparable qualified person.

Care

- The following environmental influences may have unwanted effects on the surface of the product:
 - acid rain and sour soil, high salt content in the air
 - cleaning agents, fertilizer especially in flowerbeds
 - thawing salt, other chemical substances (e.g. herbicides)Protect the product by adequate means to avoid unwanted changes of the surface.

 Disconnect the product from the power supply and let it cool down, before you clean the product.

- Clean the product on a regular basis using a slightly moistened, soft and fluff-free cloth. Please also note additional supplied notes on maintenance and care.
- Remove leaves and dirt regularly.

STORAGE AND DISPOSAL

Storage

- The product must be stored in a dry and clean environment. Do not strain the product mechanically during storage.

 After a damp or soiling storage the product may only be installed after checking its condition by an approved electrician.

Disposal (European Union)





- Do not dispose the product with the regular household waste! Products marked with this sign must be disposed according to the directive (WEEE, 2012/19) on electrical and electronic devices at local collection points for such devices!

INSTALLATION (only by an approved electrician)

 Switch off the mains or respectively the connection lead before doing any works!

 Use only parts, which are supplied with the product or are described as accessories!

 Inspect the product for loose parts inside the housing. When there are loose parts inside the housing and these are not explicitly described the product may not be installed or operated.

 Use the supplied fastening material only when it is suited for the installation background. If this is not the case use only fastening material suiting the installation background.

Unpacking

- Carefully take the product out of the packaging removing any transport safeguards.
- Before disposal of the packaging material make sure that all components of the product are removed.

Installation place

- The product is solely suited for recessed floor installation.
- LED react sensitive on high temperatures! Before installation pay attention to the expected temperature at the place of operation.

 Note that maintaining the IP class IP65/IP67 requires an appropriate connection corresponding with this IP class.

IP65: Protection against dust (dust-tight) - Protection against jetted water from all directions.

IP67: Protection against dust (dust-tight) - Protection against the penetration of water when temporarily submerged.

 Do not seal the product yourself, using additional silicon or another sealant.

 Prepare the power supply lead according to valid rules for outdoor installations.

Before Installation

- Do not remove the grease on the crews and the screw holes! The grease inhibits anodic corrosion (electrolysis). Renew the grease on the screw connections after each time the fixture has been opened.
- Carry out the installation when the weather is dry.

Installation steps (read completely before installation)

- Prepare the recess if not done yet. When installing the lighting unit outdoors provide a gravel bed, 20 cm thick, beneath the installation pot. This serves as protection from corrosion.
- Disassemble the fitting as shown in the figure.
- Direct the underground cable, in sufficient length, through the cable screwing.
- Secure the cable screwing using a suitable tool.
- Electrical Connection
 - The product must be able to be separated by an all pole separation from the current supply.
 - Equip the three wire ends with protective tubes.
 - For electric connection attach the black or brown wire (live conductor) of the connection lead with the clamp L and the blue wire (neutral conductor) of the connection lead with the clamp N. The green-yellow wire (protective conductor) of the connection lead has to be tightly connected with the earth clamp  of the product.
- Assemble the fixture in reverse order. Pay attention that the gasket fits properly. The bearing surface of the gasket must be free of dirt. Tighten the screws on the shield in a cross-wise order, to achieve an even pressure on the gasket.
- Fix the installation pot firmly in the ground.

 Check if the product functions properly and is securely fixed!

art.-no. 229383 © 03.07.2017 SLV GmbH,
Daimlerstr. 21-23, 52531 Übach-Palenberg, Germany,
Tel. +49 (0)2451 4833-0
Technical Details are subject to change.